

SUPERO®

DOUBLE-SIDED STORAGE SC417 CHASSIS SERIES

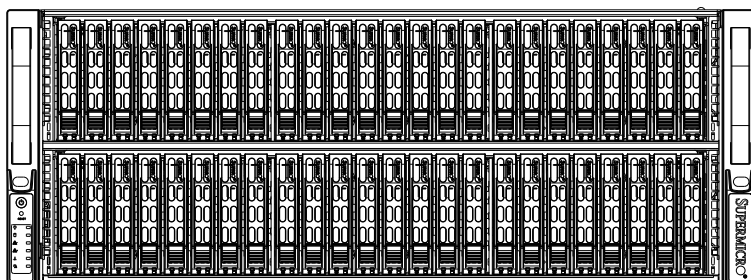

SC417E16-R1400LPB

SC417E16-R1400UB

SC417E26-R1400UB

SC417E26-R1400LPB

USER'S MANUAL

1.0

The information in this User's Manual has been carefully reviewed and is believed to be accurate. The vendor assumes no responsibility for any inaccuracies that may be contained in this document, makes no commitment to update or to keep current the information in this manual, or to notify any person or organization of the updates. **Please Note: For the most up-to-date version of this manual, please see our web site at www.supermicro.com.**

Super Micro Computer, Inc. ("Supermicro") reserves the right to make changes to the product described in this manual at any time and without notice. This product, including software and documentation, is the property of Supermicro and/or its licensors, and is supplied only under a license. Any use or reproduction of this product is not allowed, except as expressly permitted by the terms of said license.

IN NO EVENT WILL SUPERMICRO BE LIABLE FOR DIRECT, INDIRECT, SPECIAL, INCIDENTAL, SPECULATIVE OR CONSEQUENTIAL DAMAGES ARISING FROM THE USE OR INABILITY TO USE THIS PRODUCT OR DOCUMENTATION, EVEN IF ADVISED OF THE POSSIBILITY OF SUCH DAMAGES. IN PARTICULAR, SUPERMICRO SHALL NOT HAVE LIABILITY FOR ANY HARDWARE, SOFTWARE, OR DATA STORED OR USED WITH THE PRODUCT, INCLUDING THE COSTS OF REPAIRING, REPLACING, INTEGRATING, INSTALLING OR RECOVERING SUCH HARDWARE, SOFTWARE, OR DATA.

Any disputes arising between manufacturer and customer shall be governed by the laws of Santa Clara County in the State of California, USA. The State of California, County of Santa Clara shall be the exclusive venue for the resolution of any such disputes. Super Micro's total liability for all claims will not exceed the price paid for the hardware product.

California Best Management Practices Regulations for Perchlorate Materials: This Perchlorate warning applies only to products containing CR (Manganese Dioxide) Lithium coin cells. "Perchlorate Material-special handling may apply. See www.dtsc.ca.gov/hazardouswaste/perchlorate"

WARNING: Handling of lead solder materials used in this product may expose you to lead, a chemical known to the State of California to cause birth defects and other reproductive harm.

Manual Revision 1.0
Release Date: March 14, 2011

Unless you request and receive written permission from Super Micro Computer, Inc., you may not copy any part of this document.

Information in this document is subject to change without notice. Other products and companies referred to herein are trademarks or registered trademarks of their respective companies or mark holders.

Copyright © 2011 by Super Micro Computer, Inc.
All rights reserved.

Printed in the United States of America

Preface

About This Manual

This manual is written for professional system integrators and PC technicians. It provides information for the installation and use of the SC417 chassis. Installation and maintenance should be performed by experienced technicians only.

This manual lists compatible parts available when this document was published. Always refer to the our Web site for updates on supported parts and configurations.

Manual Organization

Chapter 1 Introduction

The first chapter provides a summary of the main components included with the SC417 chassis and describes the main features of the chassis. This chapter also includes contact information.

Chapter 2 System Safety

This chapter lists warnings, precautions, and system safety. It is recommended that you thoroughly familiarize yourself with installing and servicing the chassis and all safety precautions.

Chapter 3 System Interface

Refer to this chapter for details on the system interface, which includes the functions and information provided by the chassis control panel, as well as other LEDs located throughout the system.

Chapter 4 Chassis Setup and Maintenance

Refer here for details on this chassis components including the fans, hard drives, air shrouds, and other components. Follow the procedures given in this chapter when installing, removing, or reconfiguring components in your chassis.

Chapter 5 Rack Installation

This chapter provides diagrams and information on connectivity configurations for the SC417 chassis.

Appendix A Hardware

This section provides information on cabling, and other hardware which is compatible with your chassis. For complete information on supported cables and hardware, refer to the Supermicro Web site at www.supermicro.com.

Appendix B Power Supply Specifications

This chapter lists the specifications of the power supply provided with your chassis. For additional information, refer to the Supermicro website at www.supermicro.com.

Appendix C SAS2-216EL Backplane Specifications

This section contains detailed specifications on the SAS2-216EL backplane. Additional information can be found on the Supermicro Web site at www.supermicro.com.

Table of Contents

Chapter 1 Introduction

1-1	Overview	1-1
1-2	Shipping List.....	1-1
1-3	Where to get Replacement Components.....	1-2
1-4	Contacting Supermicro.....	1-3
1-5	Returning Merchandise for Service.....	1-4

Chapter 2 System Safety

2-1	Overview	2-1
2-2	Warnings and Precautions	2-1
2-3	Preparing for Setup.....	2-1
2-4	Electrical Safety Precautions	2-2
2-5	General Safety Precautions	2-3
2-6	System Safety.....	2-3

Chapter 3 System Interface

3-1	Overview	3-1
3-2	Control Panel Buttons	3-2
3-3	Control Panel LEDs	3-2
3-4	Drive Carrier LEDs.....	3-4
	SAS/SATA Drives	3-4
	SCSI Drives.....	3-4

Chapter 4 Chassis Setup and Maintenance

4-1	Overview	4-1
4-2	Removing the Chassis Cover	4-2
4-3	Installing Removable Hard Drives.....	4-3
4-4	Installing Optional Fixed Hard Drives	4-6
4-5	Installing the Motherboard	4-8
	Permanent and Optional Standoffs.....	4-8
	PCI Slot Setup	4-10
	Expansion Slot Setup in LP (Low Profile) Chassis.....	4-10
	Expansion Slot Setup in U (Universal Output) Chassis	4-11
4-6	Installing the Air Shroud.....	4-12
4-7	Checking the Server's Air Flow.....	4-13
4-8	System Fans	4-14
4-9	Power Supply	4-16

Chapter 5 Rack Installation

5-1	Overview	5-1
5-2	Unpacking the System	5-1
5-3	Preparing for Setup	5-1
	Choosing a Setup Location	5-1
5-4	Warnings and Precautions	5-2
	Rack Precautions	5-2
	General Server Precautions	5-2
5-5	Rack Mounting Considerations	5-3
	Ambient Operating Temperature	5-3
	Reduced Airflow	5-3
	Mechanical Loading	5-3
	Circuit Overloading	5-3
	Reliable Ground	5-3
5-6	Rack Mounting Instructions	5-4
	Identifying the Sections of the Rack Rails	5-4
	Locking Tabs	5-5
	Releasing the Inner Rail	5-5
	Installing The Inner Rails on the Chassis	5-6
	Installing the Outer Rails on the Rack	5-7
	Standard Chassis Installation	5-8
	Optional Quick Installation Method	5-9
	Adapters for Round and Threaded Hole Racks	5-10

Appendix A SC417 Cables and Hardware**Appendix B SC417 Power Supply Specifications****Appendix C SAS2-216EL1/EL2 Backplane Specifications**

Notes

Chapter 1

Introduction

1-1 Overview

The SC417 chassis features extremely high storage density with a maximum of seventy-two 2.5" hot-swappable drives per enclosure. The chassis also features high-availability with 1400 Watt Gold Level (1+1) redundant power supplies and seven 8 cm hot-swappable cooling fans. The SC417 series chassis is ideal for DB/file servers, data warehouses, media stream servers, video on demand, security servers and other applications.

1-2 Shipping List

Please visit the Supermicro Web site for the latest shipping lists and part numbers for your particular chassis model at <http://www.supermicro.com>.

SC417 Chassis				
Model	CPU	HDD	I/O Slots	Power Supply
SC417E16-R1400LPB	DP/UP	72x SAS/SATA SAS2 support	7x LP	1400W redundant (Gold Level)
SC417E16-R1400UB	DP/UP	72x SAS/SATA SAS2 support	4x FF + 3 LP (UIO)	1400W redundant (Gold Level)
SC417E26-R1400LPB	DP/UP	72x SAS/SATA SAS2 support	7x LP	1400W redundant (Gold Level)
SC417E26-R1400UB	DP/UP	72x SAS/SATA SAS2 support	4x FF + 3 LP (UIO)	1400W redundant (Gold Level)

1-3 Where to get Replacement Components

Although not frequently, you may need replacement parts for your system. To ensure the highest level of professional service and technical support, we strongly recommend purchasing exclusively from our Supermicro Authorized Distributors/System Integrators/Resellers. A list of Supermicro Authorized Distributors/System Integrators/Resellers can be found at: <http://www.supermicro.com>. Click the Where to Buy link.

1-4 Contacting Supermicro

Headquarters

Address: Super Micro Computer, Inc.
980 Rock Ave.
San Jose, CA 95131 U.S.A.

Tel: +1 (408) 503-8000

Fax: +1 (408) 503-8008

Email: marketing@supermicro.com (General Information)
support@supermicro.com (Technical Support)

Web Site: www.supermicro.com

Europe

Address: Super Micro Computer B.V.
Het Sterrenbeeld 28, 5215 ML
's-Hertogenbosch, The Netherlands

Tel: +31 (0) 73-6400390

Fax: +31 (0) 73-6416525

Email: sales@supermicro.nl (General Information)
support@supermicro.nl (Technical Support)
rma@supermicro.nl (Customer Support)

Asia-Pacific

Address: Super Micro Computer, Inc.
4F, No. 232-1, Liancheng Rd.
Chung-Ho 235, Taipei County
Taiwan, R.O.C.

Tel: +886-(2) 8226-3990

Fax: +886-(2) 8226-3991

Web Site: www.supermicro.com.tw

Technical Support:

Email: support@supermicro.com.tw

Tel: 886-2-8226-1900

1-5 Returning Merchandise for Service

A receipt or copy of your invoice marked with the date of purchase is required before any warranty service will be rendered. You can obtain service by calling your vendor for a Returned Merchandise Authorization (RMA) number. When returning to the manufacturer, the RMA number should be prominently displayed on the outside of the shipping carton, and mailed prepaid or hand-carried. Shipping and handling charges will be applied for all orders that must be mailed when service is complete.

For faster service, RMA authorizations may be requested online (<http://www.supermicro.com/support/rma/>).

Whenever possible, repack the chassis in the original Supermicro carton, using the original packaging material. If these are no longer available, be sure to pack the chassis securely, using packaging material to surround the chassis so that it does not shift within the carton and become damaged during shipping.

This warranty only covers normal consumer use and does not cover damages incurred in shipping or from failure due to the alteration, misuse, abuse or improper maintenance of products.

During the warranty period, contact your distributor first for any product problems.

Chapter 2

System Safety

2-1 Overview

This chapter provides a quick setup to get your chassis up and running. Following the steps in order given should enable you to have your chassis set up and operational within a minimal amount of time. This quick setup assumes that you are an experienced technician, familiar with common concepts and terminology.

2-2 Warnings and Precautions

You should inspect the box the chassis was shipped in and note if it was damaged in any way. If the chassis itself shows damage, file a damage claim with carrier who delivered your system.

Decide on a suitable location for the rack unit that will hold that chassis. It should be situated in a clean, dust-free area that is well ventilated. Avoid areas where heat, electrical noise and electromagnetic fields are generated.

The SC417 chassis includes redundant power supplies which require two grounded outlets.

2-3 Preparing for Setup

The SC417 chassis includes a set of rail assemblies which includes mounting brackets and the mounting screws you will need to install the system into a rack. Read this manual in its entirety before you begin the installation procedure.

2-4 Electrical Safety Precautions

Basic electrical safety precautions should be followed to protect yourself from harm and the SC417 from damage:

- Be aware of the locations of the power on/off switch on the chassis as well as the room's emergency power-off switch, disconnection switch or electrical outlet. If an electrical accident occurs, you can then quickly remove power from the system.
- Do not work alone when working with high-voltage components.
- Power should always be disconnected from the system when removing or installing main system components, such as the serverboard, memory modules (not necessary for hot-swappable drives). When disconnecting power, you should first power down the system with the operating system and then unplug the power cords from all the power supply modules in the system.
- When working around exposed electrical circuits, another person who is familiar with the power-off controls should be nearby to switch off the power, if necessary.
- Use only one hand when working with powered-on electrical equipment. This is to avoid making a complete circuit, which will cause electrical shock. Use extreme caution when using metal tools, which can easily damage any electrical components or circuit boards they come into contact with.
- Do not use mats designed to decrease electrostatic discharge as protection from electrical shock. Instead, use rubber mats that have been specifically designed as electrical insulators.
- The power supply power cord must include a grounding plug and must be plugged into a grounded electrical outlet.
- Serverboard battery: CAUTION - There is a danger of explosion if the onboard battery is installed upside down, which will reverse its polarities This battery must be replaced only with the same or an equivalent type recommended by the manufacturer. Dispose of used batteries according to the manufacturer's instructions.

- Please handle used batteries carefully. Do not damage the battery in any way; a damaged battery may release hazardous materials into the environment. Do not discard a used battery in the garbage or a public landfill. Please comply with the regulations set up by your local hazardous waste management agency to dispose of your used battery properly.

2-5 General Safety Precautions

- Keep the area around the chassis clean and free of clutter.
- Place the chassis top cover and any system components that have been removed away from the system or on a table so that they won't accidentally be stepped on.
- While working on the system, do not wear loose clothing such as neckties and unbuttoned shirt sleeves, which can come into contact with electrical circuits or be pulled into a cooling fan.
- Remove any jewelry or metal objects from your body, which are excellent metal conductors that can create short circuits and harm you if they come into contact with printed circuit boards or areas where power is present.
- After accessing the inside of the system, close the system back up and secure it to the rack unit with the retention screws after ensuring that all connections have been made.

2-6 System Safety

Electrostatic discharge (ESD) is generated by two objects with different electrical charges coming into contact with each other. An electrical discharge is created to neutralize this difference, which can damage electronic components and printed circuit boards. The following measures are generally sufficient to neutralize this difference before contact is made to protect your equipment from ESD:

- Do not use mats designed to decrease electrostatic discharge as protection from electrical shock. Instead, use rubber mats that have been specifically designed as electrical insulators.
- Use a grounded wrist strap designed to prevent static discharge.
- Keep all components and printed circuit boards (PCBs) in their antistatic bags until ready for use.

- Touch a grounded metal object before removing any board from its antistatic bag.
- Do not let components or PCBs come into contact with your clothing, which may retain a charge even if you are wearing a wrist strap.
- Handle a board by its edges only; do not touch its components, peripheral chips, memory modules or contacts.
- When handling chips or modules, avoid touching their pins.
- Put the serverboard and peripherals back into their antistatic bags when not in use.
- For grounding purposes, make sure your computer chassis provides excellent conductivity between the power supply, the case, the mounting fasteners and the serverboard.

Chapter 3

System Interface

3-1 Overview

There are six LEDs on the front control panel as well as others on the drive carriers to keep you constantly informed of the overall status of the system and over-all health of specific components. SC417 models have two buttons on the chassis control panel: A reset button and a power on/off switch. This chapter explains the meanings of all LED indicators and the appropriate responses you may need to take.

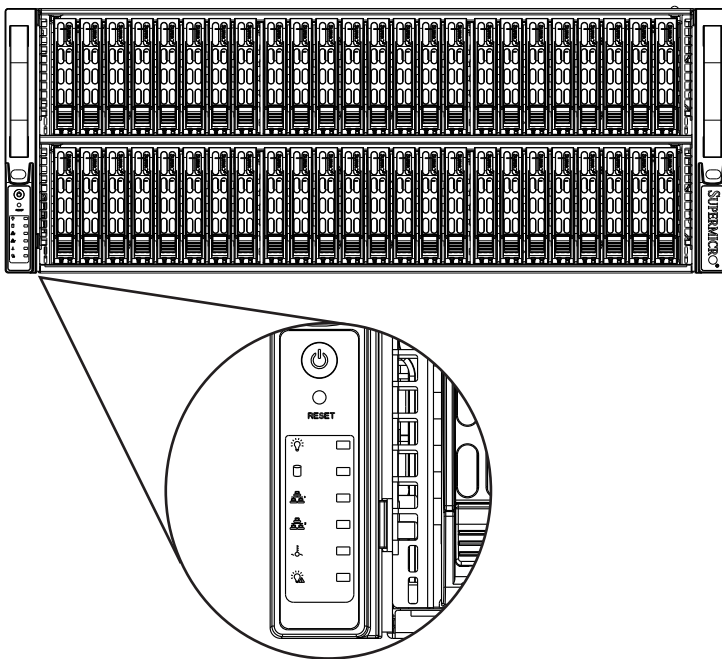

Figure 3-1: Control Panel

3-2 Control Panel Buttons

There are two push-buttons located on the left handle of the chassis. From top to bottom these are a power on/off button and a reset button.



Power: The main power button is used to apply or remove power from the power supply to the system. Turning off system power with this button removes the main power but keeps standby power supplied to the system. Therefore, you must unplug system before servicing.

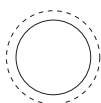

Reset: The reset button is used to reboot the system.

3-3 Control Panel LEDs

The control panel is located on the left handle of the SC417 chassis and has six LEDs. These LEDs provide you with critical information related to different parts of the system. This section explains what each LED indicates when illuminated and any corrective action you may need to take.



Power: Indicates power is being supplied to the system's power supply units. This LED should normally be illuminated when the system is operating.



HDD: Indicates IDE channel activity. SAS/SATA drive, and/or DVD-ROM drive activity when flashing.



NIC1: Indicates network activity on GLAN1 when flashing.



NIC2: Indicates network activity on GLAN2 when flashing.



Overheat/Fan Fail: When this LED flashes, it indicates a fan failure. When continuously on (not flashing) it indicates an overheat condition, which may be caused by cables obstructing the airflow in the system or the ambient room temperature being too warm. Check the routing of the cables and make sure all fans are present and operating normally. You should also check to make sure that the chassis covers are installed. Finally, verify that the heatsinks are installed properly. This LED will remain flashing or on as long as the overheat condition exists.



Power Failure: When this LED flashes, it indicates a failure in the redundant power supply.

3-4 Drive Carrier LEDs

The SC417 chassis uses SAS or SATA drives.

SAS/SATA Drives

Each SAS/SATA drive carrier has two LEDs.

- **Blue:**

Solid on = Drive is present and available.

Blinking = Drive is actively being accessed.

Each Serial ATA drive carrier has a blue LED. When illuminated in a solid on state, this blue LED (on the front of the SAS/SATA drive carrier) indicates drive activity. A connection to the SAS/SATA backplane enables this LED to blink on and off when that particular drive is being accessed.

- **Red:**

Solid on = Drive failure

Blinking = RAID activity

When the red LED is blinking, it indicates that the system is either building, initializing or rebuilding RAID.

SCSI Drives

This chassis does not support SCSI drives at this time.

Chapter 4

Chassis Setup and Maintenance

4-1 Overview

This chapter covers the steps required to install components and perform maintenance on the chassis. The only tool you will need to install components and perform maintenance is a Phillips screwdriver. Print this chapter to use as a reference while setting up your chassis.



Review the warnings and precautions listed in the manual before setting up or servicing this chassis. These include information in Chapter 2: System Safety and the warnings/precautions listed in the setup instructions.



Safety Warning: Before performing any chassis setup or maintenance, it is recommended that the chassis be removed from the rack and placed on a stable bench or table. For instructions on how to uninstall the chassis from the rack, refer to Chapter 5 Rack Installation in this manual.

4-2 Removing the Chassis Cover

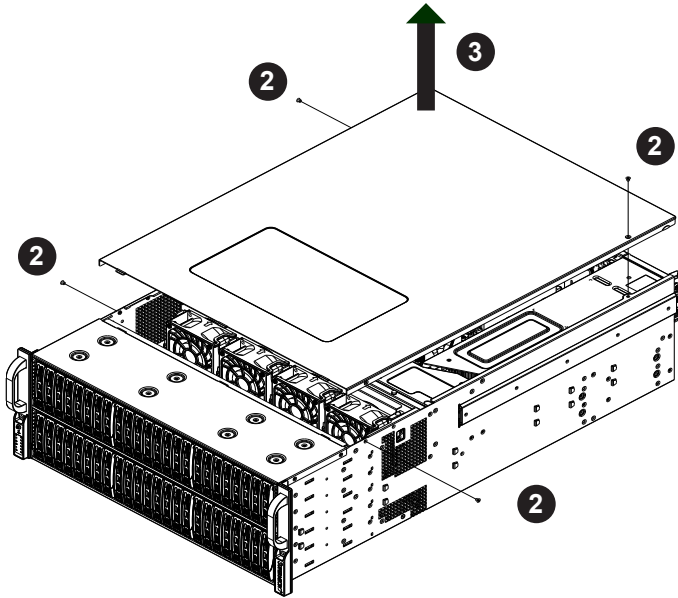

Figure 4-1: Removing the Chassis Cover

Removing the Chassis Cover

1. Unplug the chassis from any power source
2. Remove the screws securing the cover to the chassis.
3. Lift the cover up and off the chassis.



Warning: Except for short periods of time, do NOT operate the server without the cover in place. The chassis cover must be in place to allow proper airflow and prevent overheating.

4-3 Installing Removable Hard Drives

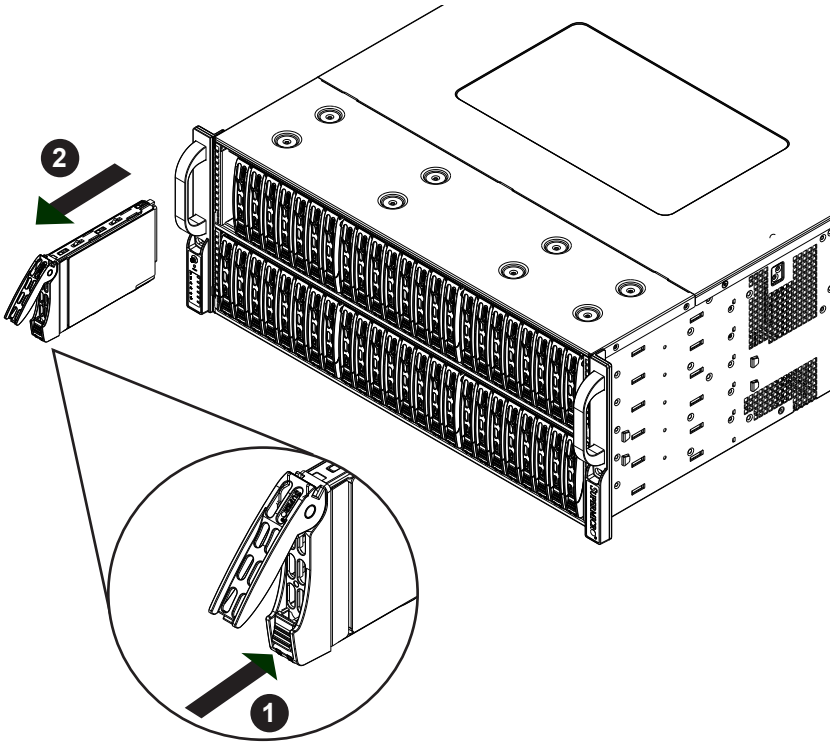

Figure 4-2: Removing Hard Drive

Removing Hard Drive Carriers from the Chassis

1. Press the release button on the drive carrier. This extends the drive carrier handle.
2. Use the handle to pull the drive carrier out of the chassis.

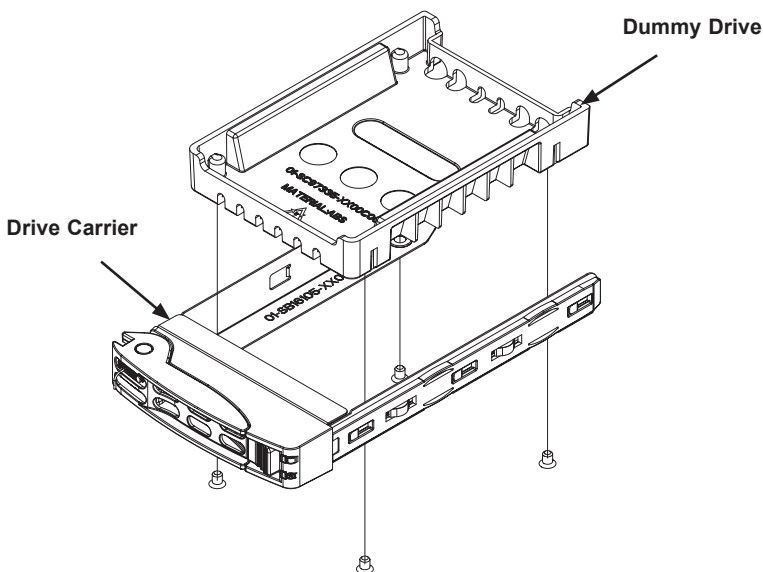

Figure 4-3: Chassis Drive Carrier

The 2.5" drives are mounted in drive carriers to simplify their installation and removal from the chassis. These carriers also help to promote proper airflow for the drive bays.



Warning: Except for short periods of time (while swapping hard drives), do not operate the server with the drives removed from the chassis drive bays.



Warning! Enterprise level hard disk drives are recommended for use in Supermicro chassis and servers. For information on recommended HDDs, visit the Supermicro

Installing a Hard Drive to the Hard Drive Carrier

1. Remove the four screws securing the dummy drive to the drive carrier and remove the dummy drive.

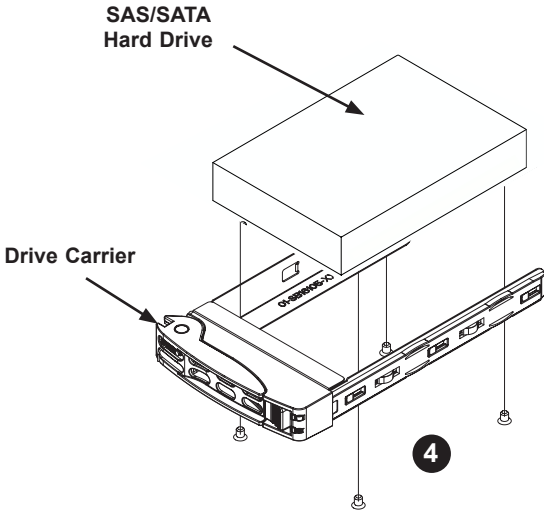

Figure 4-5: Installing the Hard Drive into the Carrier

2. Place the hard drive into the carrier with the printed circuit board side facing down.
3. Carefully align the mounting holes in the drive carrier with the holes in the hard drive.
4. Secure the hard drive to the carrier using four screws.
5. Replace the drive tray into the chassis. Make sure to close the drive carrier handle to lock the drive carrier into place.

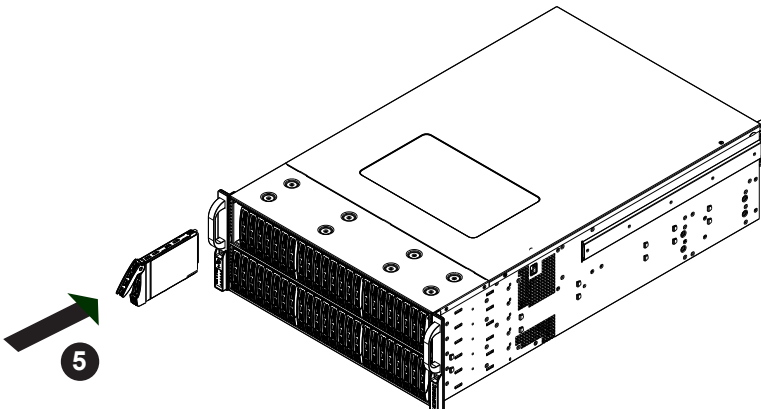

Figure 4-6: Installing the Hard Drive

4-4 Installing Optional Fixed Hard Drives

The SC417 chassis includes brackets for installing either one 3.5" fixed hard drive, or two 2.5" fixed hard drives within the chassis. Each chassis can accommodate up to two internal drive trays supporting up to two 3.5" hard drives or up to four 2.5" hard drives. The tray part number is MCP-220-84701-0N.

Installing Fixed HDDs into the SC417 Chassis

1. Disconnect the chassis from any power source.
2. Remove the chassis cover as described in Section 4-2.
3. Remove the screw securing the motherboard node tray to the chassis.
4. Slide back the motherboard node tray to reveal the HDD mounting location on the floor of the chassis.

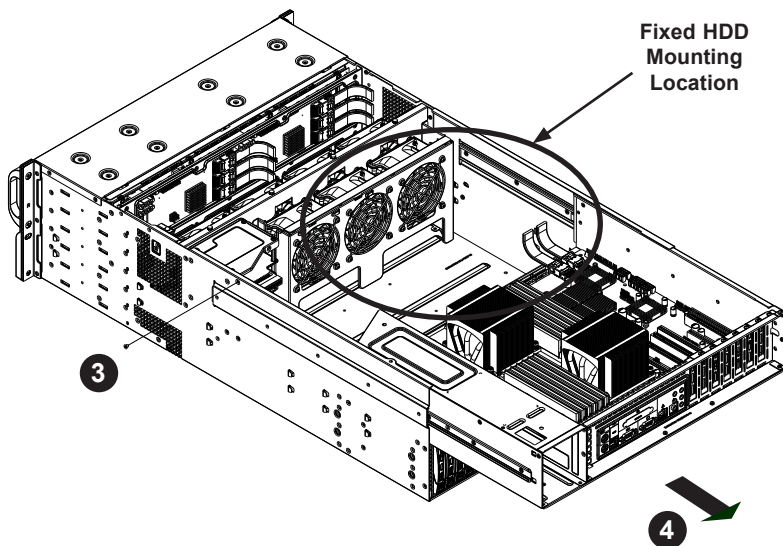

Figure 4-7: Sliding Back the Motherboard Node Tray

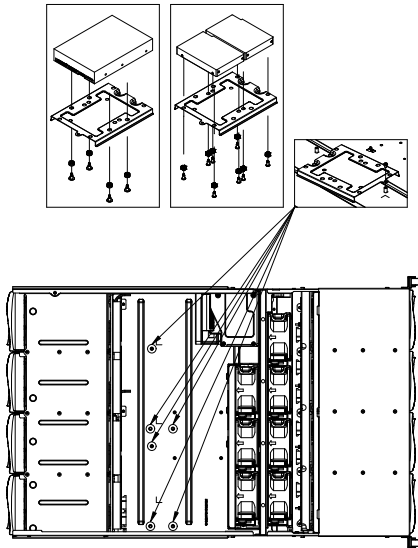

Figure 4-8: Installing Single and Dual Hard Drives and the Bracket

Installing a 3.5" Single Hard Drive into the Bracket

1. Align the four round washers and four screws with the holes in the hard drive and the holes in the bracket.
2. Secure the hard drive to the bracket using the screws and washers provided.
3. See the instructions below for installing the bracket onto the chassis.

Installing Dual 2.5" Hard Drives into the Bracket

1. Align the eight external tooth washers and eight screws with the holes in the hard drive and the holes in the bracket.
2. Secure the hard drive to the bracket using the screws and washers provided.
3. See the instructions below for installing the bracket onto the chassis.

Installing the Bracket onto the Chassis

1. Align the holes in the bracket with the chassis standoffs.
2. Secure the bracket using the screws provided.

4-5 Installing the Motherboard

Permanent and Optional Standoffs

Standoffs prevent short circuits by securing space between the motherboard and the chassis surface. The SC417 chassis includes permanent standoffs in locations used by most motherboards. These standoffs accept the rounded Phillips head screws included in the SC417 accessories packaging.

Some motherboards require additional screws for heatsinks, general components and/or non-standard security. Optional standoffs are included to these motherboards. To use an optional standoff, you must place the hexagonal screw through the bottom the chassis and secure the screw with the hexagon nut (rounded side up).



M/B standoff
6-32 to 6-32

Figure 4-11: Chassis Standoffs

Installing the Motherboard

1. Review the documentation that came with your motherboard. Become familiar with component placement, requirements, precautions, and cable connections.
2. Open the chassis cover and remove the chassis from any power source.
3. As required by your motherboard, install standoffs in any areas that do not have a permanent standoff. Compare the mounting holes in the motherboard to those in the chassis.
 - A. Place a hexagonal standoff screw through the bottom the chassis.
 - B. Secure the screw with the hexagon nut (rounded side up).

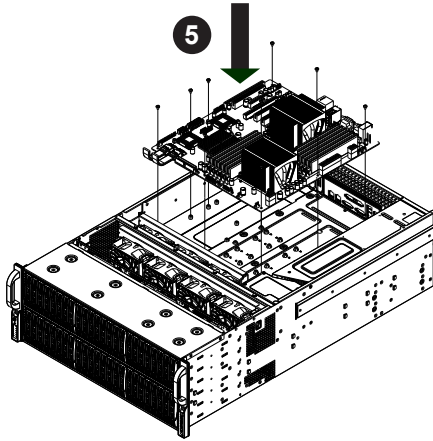

Figure 4-9: Motherboard Installation

4. Lay the motherboard on the chassis aligning the permanent and optional standoffs. Compare the mounting holes in the motherboard to those in the chassis.
5. Secure the motherboard to the chassis using the rounded, Phillips head screws. Do not exceed eight pounds of torque per square inch when tightening down the motherboard.
6. Secure the CPU(s), heatsinks, and other components to the motherboard as described in the motherboard documentation.
7. Slide back the motherboard tray and connect the cables between the motherboard, backplane, chassis, front panel, and power supply as needed. The fans may be temporarily removed to allow access to the backplane ports.

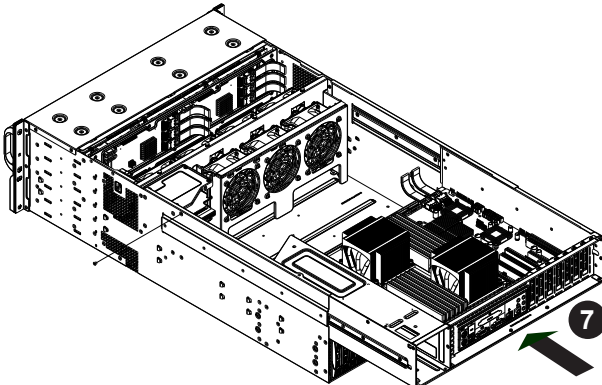

Figure 4-10: Slide Back the Motherboard Tray

PCI Slot Setup

SC417: The chassis includes PCI slots for expansion cards. The number of cards used depends on your chassis model.

SC417 LP Models: Provides seven low-profile PCI card slots for expansion cards.

SC417 UIO Models: Provides four full-height/full-length slots, three low-profile slots and includes a universal expansion card.

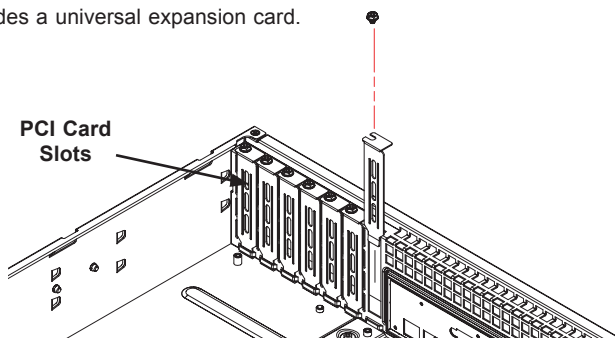

Figure 4-12: SC417 LP model

Expansion Slot Setup in LP (Low Profile) Chassis

The SC417 chassis includes PCI slots for expansion cards. The number of cards you can use depends upon your chassis model and motherboard model.

Installing Expansion Cards in SC417 LP (Low Profile) Chassis

1. Disconnect the power supply, lay the chassis on a flat surface, and open the chassis cover.
2. Remove the screw holding the cover in place for each low profile expansion card slot you want to use. Keep this screw for later use.
3. Connect the expansion cards to the motherboard.
4. Secure each card to the chassis using the card's L-bracket and the screw previously removed.

Expansion Slot Setup in U (Universal Output) Chassis

SC417 U model chassis accepts a slightly smaller "L" shaped motherboard to allow for a universal expansion card to be used. This universal output card allows the systems to accept SAS, SCSI, IB, Ethernet, and other types of connections.

SC417 U chassis accepts three full-length, full-height expansion cards and the fourth slot is used for the UI/O card. It includes a bracket that extends from the fan row to the back of the chassis. This bracket provides support for the riser card.

Installing a Universal Input/Output Card in the SC417 U Model Chassis

1. Disconnect the power supply, lay the chassis on a flat surface, and open the chassis cover.
2. Connect the universal input/output to the motherboard using the slots provided on the motherboard and the back panel.
3. Secure the card to the chassis using the four screws provided in the chassis packaging.

The SC417 U model chassis includes four full-height/full-length slots and three low-profile slots.

Installing Expansion Cards in the SC417 U Chassis

1. Disconnect the power supply, lay the chassis on a flat surface, and open the chassis cover.
2. If you are using a universal input/output card, make sure it is installed before continuing.
3. If you installing low-profile expansion cards, remove the chassis air shroud.
4. Secure the card to the chassis using the four screws provided with the chassis packaging.

4-6 Installing the Air Shroud

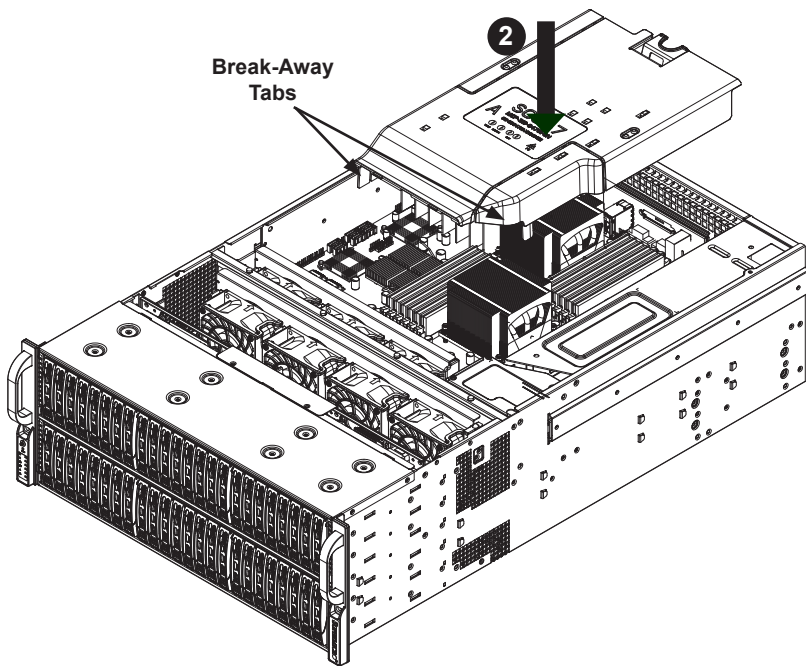

Figure 4-13: Air Shroud for the SC417 Chassis

Air shrouds concentrate airflow to maximize fan efficiency. The SC417 chassis air shroud does not require screws for its installation. The SC417 air shroud is designed with removeable break-away tabs that allow the air shroud to be adjusted to fit a variety of motherboards.

Installing the Air Shroud

1. Disconnect the chassis from any power source and remove the chassis cover.
2. Place the air shroud in the chassis. The air shroud fits behind the fans and beside to the power supply.
3. After checking the fit of the air shroud, remove any break-away tabs necessary to ensure a proper fit with the motherboard.

4-7 Checking the Server's Air Flow

Checking the Air Flow

1. Make sure there are no objects to obstruct airflow in and out of the server. In addition, if you are using a front bezel, make sure that the bezel's filter is replaced periodically.
2. Do not operate the server without drives or drive trays in the drive bays. Use only the recommended server parts.
3. Make sure that no wires or foreign objects obstruct airflow through the chassis. Pull all excess cabling out of the airflow path or use shorter cables.

The control panel LEDs inform you of system status. See “Chapter 3: System Interface” for details on the LEDs and the control panel buttons.

In most cases, the chassis power supply and fans are pre-installed. If you need to install fans continue to the Systems Fan section of this chapter. If the chassis will be installed into a rack, continue to the next chapter for rack installation instructions

4-8 System Fans

Seven hot-swappable, heavy-duty fans provide cooling for the chassis. These fans circulate air through the chassis thereby lowering the chassis internal temperature.

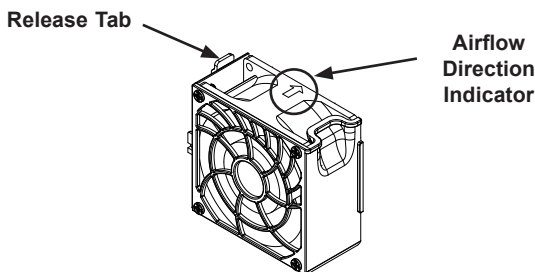

Figure 4-14: System Fan

Replacing a System Fan

1. Open the chassis while the power is running to determine which fan has failed. (Never run the server for an extended period of time with the chassis cover open.)
2. Remove the failed fan's power cord from the serverboard.
3. Press the fan release tab and lift the failed fan from the chassis.
4. Place the new fan into the vacant space in the housing while making sure the arrows on the top of the fan (indicating airflow direction) point in the same direction as the arrows on the other fans.
5. Check that the fan is working properly before replacing the chassis cover.

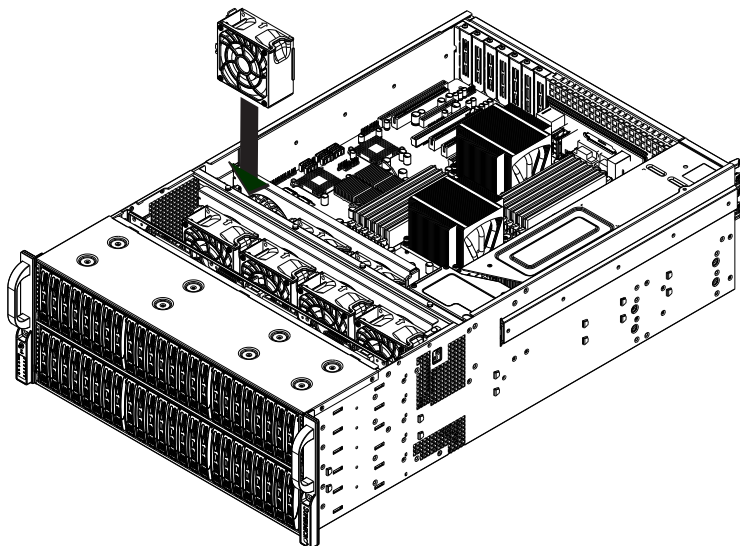

Figure 4-15: Placing the System Fan

4-9 Power Supply

The SC417 chassis has a 1400 Watt high-efficiency redundant power supply. This power supply is auto-switching capable. This enables it to automatically sense and operate at a 100v to 240v input voltage. An amber light will be illuminated on the power supply when the power is off. An illuminated green light indicates that the power supply is operating.

Redundant power supplies are hot-swappable, and can be changed without powering down the system. New units can be ordered directly from Supermicro (see contact information in the Preface).

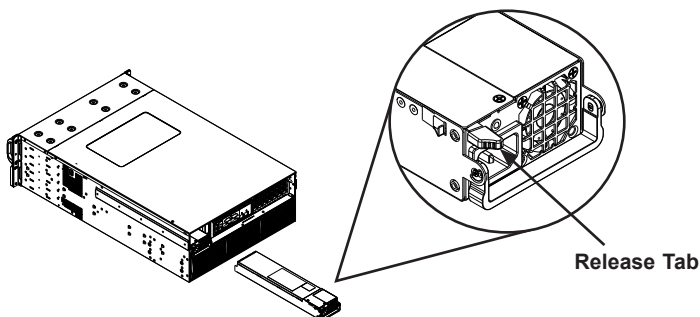

Figure 4-16: Power Supply Release Tab

Changing the Power Supply:

1. The SC417 chassis includes a redundant power supply. This means that the power supply may be replaced without powering-down the server. If your chassis has only one power supply, you must power-down the server and unplug the power cord.
2. Push the release tab (on the back of the power supply) as illustrated.
3. Pull the power supply out using the handle provided.
4. Replace the failed power module with the same model.
5. Push the new power supply module into the power bay until it clicks into the locked position.
6. Plug the AC power cord back into the module and power up the server.

Chapter 5

Rack Installation

5-1 Overview

This chapter provides instructions for installing the chassis into a rack. Follow the instructions in the order given to ensure that the system is mounted correctly.

5-2 Unpacking the System

You should inspect the box which the chassis was shipped in and note if it was damaged in any way. If the chassis itself shows damage, you should file a damage claim with the carrier who delivered it.

Decide on a suitable location for the rack unit that will hold your chassis. It should be situated in a clean, dust-free area that is well ventilated. Avoid areas where heat, electrical noise and electromagnetic fields are generated. The system needs to be placed near a grounded power outlet. Be sure to read the Rack and Server Precautions in the next section.

5-3 Preparing for Setup

The box your chassis was shipped in should include two sets of rail assemblies and the mounting screws required to install the system into a rack. Also included is an optional square hole to round hole converter bracket, for use in racks with round mounting holes. *Please read this section in its entirety before beginning the installation procedures outlined in the following sections.*

Choosing a Setup Location

- Leave enough clearance in front of the rack to enable you to open the front door completely (~25 inches).
- Leave approximately 30 inches of clearance in the back of the rack to allow for sufficient airflow and ease in servicing.
- This product is for installation only in a Restricted Access Location (dedicated equipment rooms, service closets and similar environments).



Warning!



5-4 Warnings and Precautions

Rack Precautions

- Ensure that the leveling jacks on the bottom of the rack are fully extended to the floor with the full weight of the rack resting on them.
- In single rack installations, stabilizers should be attached to the rack.
- In multiple rack installations, the racks should be coupled together.
- Always make sure that the rack is stable before extending a component from the rack.
- You should extend only one component at a time - extending two or more simultaneously may cause the rack to become unstable.

General Server Precautions

- Review the electrical and general safety precautions that came with the components you are adding to your chassis.
- Determine the placement of each component in the rack *before* you install the rails.
- Install the heaviest server components on the bottom of the rack first, and then work upwards.
- Use a regulating uninterruptible power supply (UPS) to protect the server from power surges, voltage spikes and to keep your system operating in case of a power failure.
- Allow the hot-plug hard drives and power supply modules to cool before touching them.

- Always keep the rack's front door and all panels and components on the servers closed when not servicing to maintain proper cooling.

5-5 Rack Mounting Considerations

Ambient Operating Temperature

If installed in a closed or multi-unit rack assembly, the ambient operating temperature of the rack environment may be greater than the ambient temperature of the room. Therefore, consideration should be given to installing the equipment in an environment compatible with the manufacturer's maximum rated ambient temperature (TMRA).

Reduced Airflow

Equipment should be mounted into a rack so that the amount of airflow required for safe operation is not compromised.

Mechanical Loading

Equipment should be mounted into a rack so that a hazardous condition does not arise due to uneven mechanical loading.

Circuit Overloading

Consideration should be given to the connection of the equipment to the power supply circuitry and the effect that any possible overloading of circuits might have on overcurrent protection and power supply wiring. Appropriate consideration of equipment nameplate ratings should be used when addressing this concern.

Reliable Ground

A reliable ground must be maintained at all times. To ensure this, the rack itself should be grounded. Particular attention should be given to power supply connections other than the direct connections to the branch circuit (i.e. the use of power strips, etc.).

5-6 Rack Mounting Instructions

This section provides information on installing the chassis into a rack unit with the rails provided. There are a variety of rack units on the market, which may mean that the assembly procedure will differ slightly from the instructions provided. You should also refer to the installation instructions that came with the rack unit you are using. **NOTE:** This rail will fit a rack between 26.5" and 36.4" deep.

Identifying the Sections of the Rack Rails

The chassis package includes two rail assemblies in the rack mounting kit. Each assembly consists of three sections: An inner chassis rail which secures directly to the chassis, an outer rail that secures to the rack, and a middle rail which extends from the outer rail. These assemblies are specifically designed for the left and right side of the chassis.

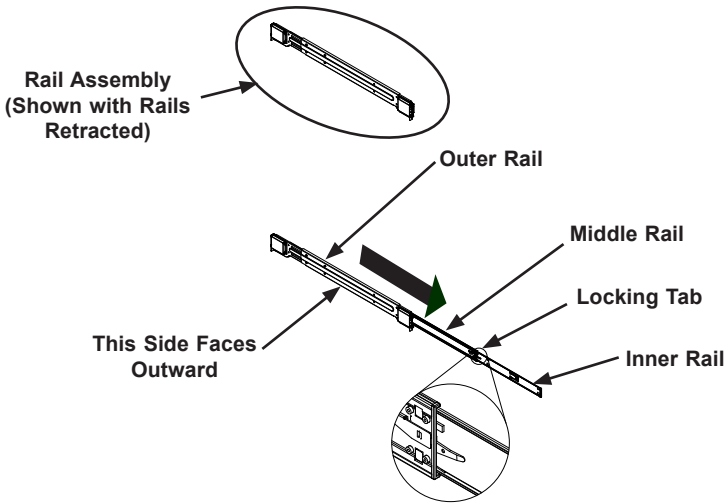

Figure 5-1: Identifying the Outer Rail, Middle Rail and Inner Rails (Left Rail Assembly Shown)

Locking Tabs

Each inner rail has a locking tab. This tab locks the chassis into place when installed and pushed fully into the rack. These tabs also lock the chassis in place when fully extended from the rack. This prevents the server from coming completely out of the rack when the chassis is pulled out for servicing.

Releasing the Inner Rail

Releasing Inner Rail from the Outer Rails

1. Identify the left and right outer rail assemblies as described on page 5-4.
2. Pull the inner rail out of the outer rail until it is fully extended as illustrated below.
3. Press the locking tab down to release the inner rail.
4. Pull the inner rail all the way out.
5. Repeat steps 1-3 for the second outer rail.

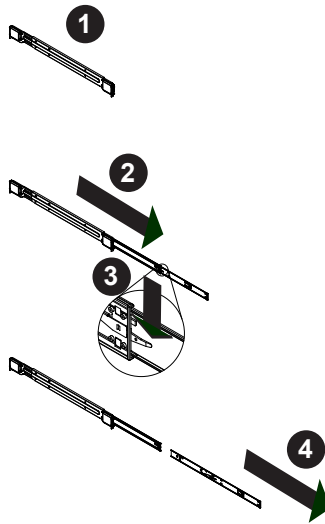

Figure 5-2: Extending and Releasing the Inner Rail

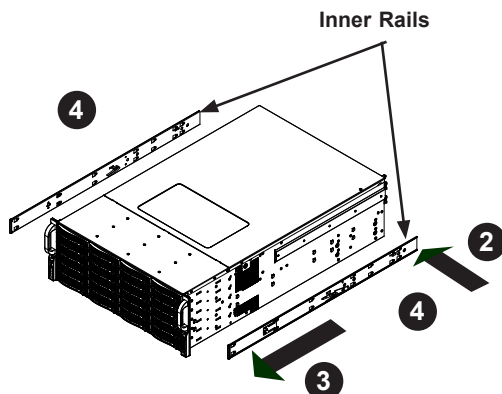

Figure 5-3: Installing the Inner Rails

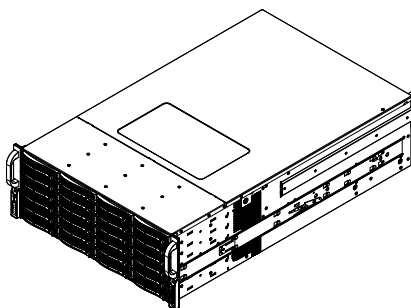

Figure 5-4: Inner Rails Installed on the Chassis

Installing The Inner Rails on the Chassis

Installing the Inner Rails

1. Confirm that the left and right inner rails have been correctly identified.
2. Place the inner rail firmly against the side of the chassis, aligning the hooks on the side of the chassis with the holes in the inner rail.
3. Slide the inner rail forward toward the front of the chassis until the rail clicks into the locked position, which secures the inner rail to the chassis.
4. Secure the inner rail to the chassis with the screws provided.
5. Repeat steps 1 through 4 above for the other inner rail.

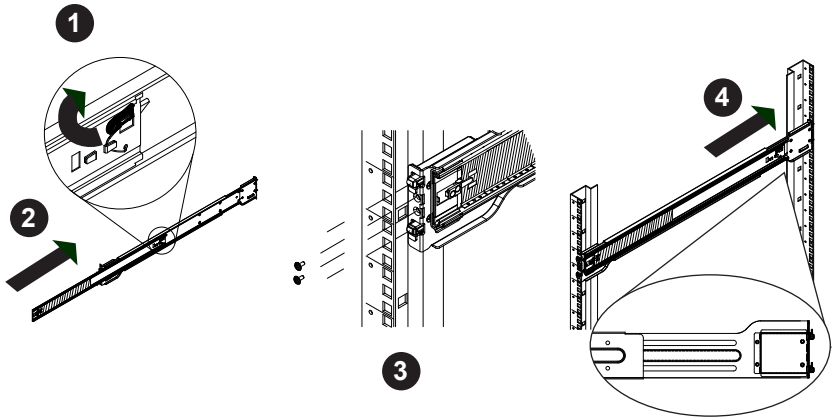

Figure 5-5: Extending and Releasing the Outer Rails

Installing the Outer Rails on the Rack

Installing the Outer Rails

1. Press upward on the locking tab at the rear end of the middle rail.
2. Push the middle rail back into the outer rail.
3. Hang the hooks of the front of the outer rail onto the slots on the front of the rack. If necessary, use screws to secure the outer rails to the rack, as illustrated above.
4. Pull out the rear of the outer rail, adjusting the length until it fits within the posts of the rack.
5. Hang the hooks of the rear portion of the outer rail onto the slots on the rear of the rack. If necessary, use screws to secure the rear of the outer rail to the rear of the rack.
6. Repeat steps 1-5 for the remaining outer rail.

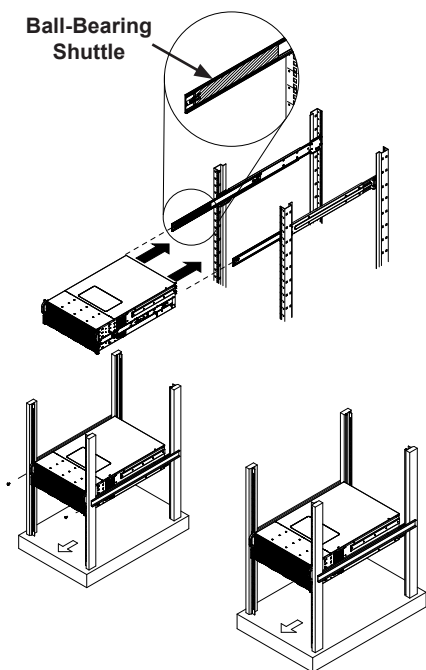

Figure 5-6: Installing into a Rack

Standard Chassis Installation

Installing the Chassis into a Rack

1. Confirm that the inner rails are properly installed on the chassis.
2. Confirm that the outer rails are correctly installed on the rack.
3. Pull the middle rail out from the front of the outer rail and make sure that the ball-bearing shuttle is at the front locking position of the middle rail.
4. Align the chassis inner rails with the front of the middle rails.
5. Slide the inner rails on the chassis into the middle rails, keeping the pressure even on both sides, until the locking tab of the inner rail clicks into the front of the middle rail, locking the chassis into the fully extended position.
6. Depress the locking tabs of both sides at the same time and push the chassis all the way into the rear of the rack.
7. If necessary for security purposes, use screws to secure the chassis handles to the front of the rack.

Optional Quick Installation Method

The following quick installation method may be used to install the chassis onto a rack.

Installing the Chassis into a Rack

1. Install the whole rail assembly onto the rack as described on page 5-7.
2. Release the inner rail without retracting the middle rail.
3. Install the inner rails on the chassis as previously described on page 5-6.
4. Install the chassis onto the middle rail as described in the previous section.

Adapters for Round and Threaded Hole Racks

The SC417 chassis includes adapter brackets for those customers using round hole racks or racks with threaded holes size M5 or larger.

Installing the Adapter Bracket

1. Place the hooks of the front of the outer rail into the square holes of one of the adapter brackets.
2. Place the hooks of the rear of the outer rail into the square holes of a second adapter bracket.
3. Adjust the length of the outer rail to fit within the rack uprights.
4. Secure the front adapter bracket to the front of the rack using the screws recommended by the rack manufacturer.
5. Secure the rear adapter bracket to the rear of the rack in the same manner.

Appendix A

SC417 Cables and Hardware

A-1 Overview

This appendix lists supported cables for your chassis system. It only includes the most commonly used components and configurations. For more compatible cables, refer to the manufacturer of the motherboard you are using and our Web site at: www.supermicro.com.

A-2 Cables Included with SC417 Chassis (SAS/SATA)

SC417			
Part #	Type	Length	Description
CBL-0088L	Cable	9"	Seven each, 10.5", 4-pin middle fan power extension (PWM)
CBL-0087	Ribbon, Round	20"	16-pin to 16-pin ribbon cable for control panel
CBL-0160L	Cable	6'	Two each, regional power cords
CBL-0217L	Cable	22cm (8.66")	16-pin control panel converter cable

A-3 Compatible Cables

These cables are compatible with the SC417 Chassis.

Alternate SAS/SATA Cables

Some compatible motherboards have different connectors. If your motherboard has only one SAS connector that the SAS/SATA cables must share, use one of the following cables. These cables must be purchased separately.

Cable Name: SAS Cable

Quantity: 1

Part #: CBL-0175L

Alt. Name: "Big Four"

Description: This cable has one SFF-8484 (32-pin) connector on one end and four SAS connectors (seven pins each) at the other. This cable connects from the host (motherboard or other controller) to the backplane SAS hard drive port.

Cable Name: SAS Cable

Quantity: 1

Part #: CBL-0116

Alt. Name: iPass or "Small Four"

Description: This cable has one iPass (SFF-8087/Mini-SAS) connector (36-pin) at one end and four SAS connectors on one end. This cable connects from the host (motherboard or other controller) to the backplane SAS hard drive port.

Extending Power Cables

Although Supermicro chassis are designed with to be efficient and cost-effective, some compatible motherboards have power connectors located in different areas.

To use these motherboards you may have to extend the power cables to the motherboards. To do this, use the following chart as a guide.

Power Cable Extenders		
Number of Pins	Cable Part #	Length
24-pin	CBL-0042	7.9" (20 cm)
20-pin	CBL-0059	7.9" (20 cm)
8-pin	CBL-0062	7.9" (20 cm)
4-pin	CBL-0060	7.9" (20 cm)

Front Panel to the Motherboard

The SC417 chassis includes a cable to connect the chassis front panel to the motherboard. If your motherboard uses a different connector, use the following list to find a compatible cable.

Front Panel to Motherboard Cable (Ribbon Cable)		
Number of Pins (Front Panel)	Number of Pins (Motherboard)	Cable Part #
16-pin	16-pin	CBL-0049
16-pin	20-pin	CBL-0048
20-pin	20-pin	CBL-0047
16-pin	Varies*	CBL-0068
20-pin	Varies*	CBL-0067

* Split cables: Use these cable if your motherboard requires several different connections from the front panel.

A-4 Chassis Screws

The accessory box includes all the screws needed to set up your chassis. This section lists and describes the most common screws used. Your chassis may not require all the parts listed.

M/B



Pan head
6-32 x 5 mm
[0.197]

HARD DRIVE



Flat head
6-32 x 5 mm
[0.197]

DVD-ROM, CD-ROM, and FLOPPY DRIVE



Pan head
6-32 x 5 mm
[0.197]



Flat head
6-32 x 5 mm
[0.197]



Round head
M3 x 5 mm
[0.197]



Round head
M2.6 x 5 mm
[0.197]

RAIL



Flat head
M4 x 4 mm
[0.157]



Round head
M4 x 4 mm
[0.157]



Flat head
M5 x 12 mm [0.472]
Washer for M5



M/B STANDOFFS



M/B standoff
6-32 to 6-32



M/B (CPU)
standoff
M5 to 6-32



Thumb screw
6-32 x 5 mm
[0.197]



1/U M/B standoff
6-32 x 5 mm
[0.197]

Appendix B

SC417 Power Supply Specifications

This appendix lists power supply specifications for your chassis system.

SC417	
	1400W
MFR Part #	PWS-1K41P-1R
AC Input	1100W: 100 - 140V, 50 - 60Hz, 9.5 - 13.5A 1400W: 180 - 240V, 50 - 60Hz, 7.0 - 9.5A
DC Output +5V Standby	4A
DC Output +12V	92A @ 100-140V 116Ap @ 180-240V
With Distributor:	
+5V	30A
+3.3V	24A
-12V	0.6Ap

Notes

Appendix C

SAS2-216EL1/EL2 Backplane Specifications

C-1 Overview of the SAS2-216EL1/EL2 Backplanes

The SAS2-216EL1/EL2 model backplanes consists of a SAS2-216EB backplane (A) with one or two SAS2-216EL daughter cards (B and C) mounted on the rear of the backplane.

The SAS2-216EL1 model consists of the SAS2-216EB backplane (A) and **one** SAS2-216EL daughter card (B), mounted on the right-hand side of the backplane.

The SAS2-216EL2 model consists of the SAS2-216EB backplane (A), and **two** SAS-216EL daughter cards (B and C), mounted on the rear of the backplane.

Components on the front side of the SAS2-216EB backplane include twenty-four SAS connectors and their respective activity and failure LEDs. Components on the rear side of the backplane include jumpers and power and fan connectors. The daughter card's components include SAS ports, flash and expander chips, and mode select jumpers.

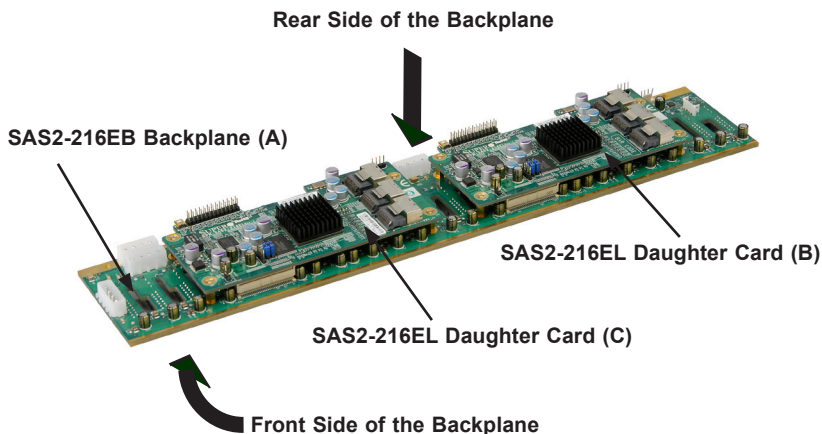

Figure C-1: Overview of the SAS2-216EL1/EL2 Backplane

Safety Guidelines

To avoid personal injury and property damage, carefully follow all the safety steps listed below when accessing your system or handling the components.

C-2 ESD Safety Guidelines

Electrostatic Discharge (ESD) can damage electronic components. To prevent damage to your system, it is important to handle the backplane very carefully. The following measures are generally sufficient to protect your equipment from ESD.

- Use a grounded wrist strap designed to prevent static discharge.
- Touch a grounded metal object before removing a component from the antistatic bag.
- Handle the backplane and daughter cards by their edges only; do not touch the components, peripheral chips, memory modules or gold contacts.
- When handling chips or modules, avoid touching their pins.
- Put the backplane and peripherals back into their antistatic bags when not in use.

C-3 General Safety Guidelines

- Always disconnect power cables before installing or removing any components from the computer, including the backplane.
- Disconnect the power cable before installing or removing any cables from the backplane.
- Make sure that the backplane is securely and properly installed on the motherboard to prevent damage to the system due to power shortage.

C-4 An Important Note to Users

All images and layouts shown in this user's guide are based upon the latest PCB Revision available at the time of publishing. The card you have received may or may not look exactly the same as the graphics shown in this manual.

C-5 Introduction to the SAS2-216EL1/EL2 Backplane

The SAS2-216EL1/EL2 model backplane has been designed to utilize the most up-to-date technology available, providing your system with reliable, high-quality performance.

This manual reflects the SAS2-216EL Revision 1.02 backplane, the most current release available at the time of publication.

This manual also describes the SAS2-216EL daughter card, Revision 1.02, the most current release available at the time of publication. Always refer to the Supermicro Web site at www.supermicro.com for the latest updates, compatible parts and supported configurations.

Connectors, Jumpers and LEDs

C-6 Connectors

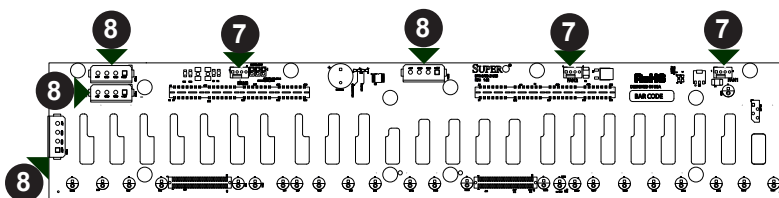

Rear of SAS2-261EB Backplane

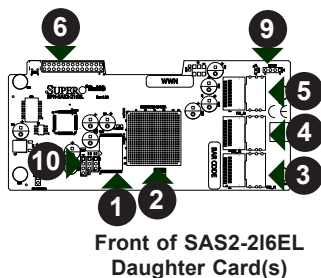

Front of SAS2-216EL
Daughter Card(s)

Figure C-2: Connectors on the Backplane and Daughter Cards

Connectors

- | | |
|---------------------|---|
| 1. Flash Chip | 6. EPP Connectors: J2 |
| 2. Expander Chip | 7. Fan Connectors: Fan1, Fan2, and Fan3 |
| 3. SAS Port: PRI_J1 | 8. Power Connectors: PWR1 - PWR4 |
| 4. SAS Port: PRI_J2 | 9. Debug Connector: EXPDBG1 |
| 5. SAS Port: PRI_J3 | 10. UART Connector: SMART_UART |

C-7 Front Connector and Pin Definitions

1. Flash Chips

The flash chip enhances the backplane memory.

2. Expander Chips

This expander chip allows the backplane to support dual ports, cascading, and failover.

3. 5. SAS Ports

The primary and secondary sets of SAS ports provide expander features including cascading and failover. From right to left the ports are Primary 1,2,3 and Secondary 1,2,3.

6. EPP Ports

The EPP ports are used for manufacturer diagnostic purposes only.

7. Fan Connectors

The 3-pin connectors, designated FAN1, FAN2, and FAN3, provide power to the fans. See the table on the right for pin definitions.

Fan Connectors	
Pin#	Definition
1	Ground
2	+12V
3	Tachometer

8. Backplane Main Power Connectors

The 4-pin connectors are designated PWR1, PWR2, PWR3 and PWR4. They provide power to the backplane. See the table on the right for pin definitions.

Backplane Main Power 4-Pin Connector	
Pin#	Definition
1	+12V
2 and 3	Ground
4	+5V

9. Debug Connector

The debug connector is designated EX-PDBG1 and is used for manufacturer's diagnostic purposes only.

10. UART Connector

The UART connector is designated SMART_UART and is used for manufacturer's diagnostic purposes only.

C-8 Jumper Locations and Settings

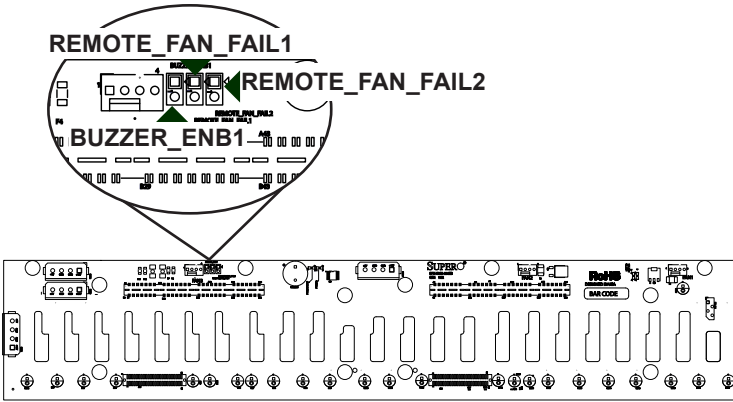

Rear of SAS2-261EB Backplane

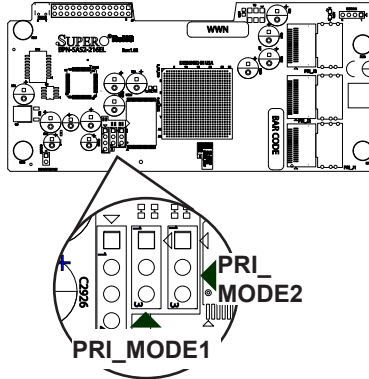

Front of SAS2-216EL Daughter Card

Figure C-3: Jumper Locations and Pin Definitions

Explanation of Jumpers

To modify the operation of the backplane, jumpers can be used to choose between optional settings. Jumpers create shorts between two pins to change the function of the connector. Pin 1 is identified with a square solder pad on the printed circuit board. Note: On two pin jumpers, "Closed" means the jumper is on and "Open" means the jumper is off the pins.

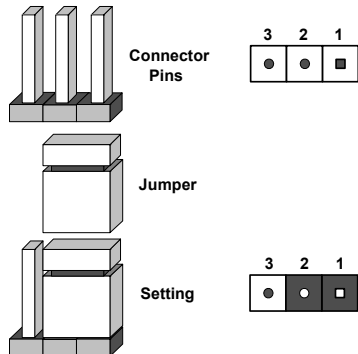

General Jumper Settings		
Jumper	Jumper Settings	Note
PRI_MODE1	Pins 2-3	Factory setting, do not change
PRI_MODE2	Pins 2-3	Factory setting do not change
REMOTE_FAN_FAIL1	Open: Enable (Default) Closed: Disable	Enables / disables the fan speed reporting.
REMOTE_FAN_FAIL2	Open: Enable (Default) Closed:Disable	Enables / disables the FAN-FAIL1 LED
BUZZER_ENB1	Open: Disable Closed: Enable	Buzzer enable*

*The buzzer sound indicates that a condition requiring immediate attention has occurred.

The buzzer alarm is triggered by any of the following conditions:

1. Hard drive failure
2. Fan failure
3. System temperature over 45° Celsius.

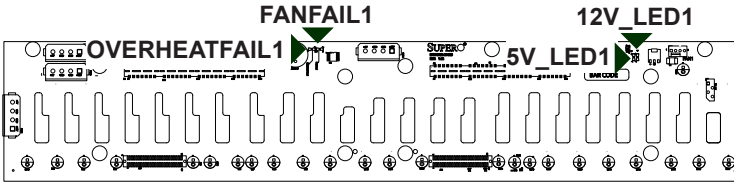

Figure C-4: Rear LEDs

Rear LEDs		
LED	Fail State	Specification
12V_LED1	Off	Green LED indicates backplane 12V power. Light is on during normal operation.
5V_LED1	Off	Blue LED indicates backplane 5V power. Light is on during normal operation.
FANFAIL1	On	Red LED indicates a fan failure. Light is off during normal operation
OVERHEATFAIL1	On	Red LED indicates an overheat condition. Light is off during normal operation

C-9 Front Connectors and LED Indicators

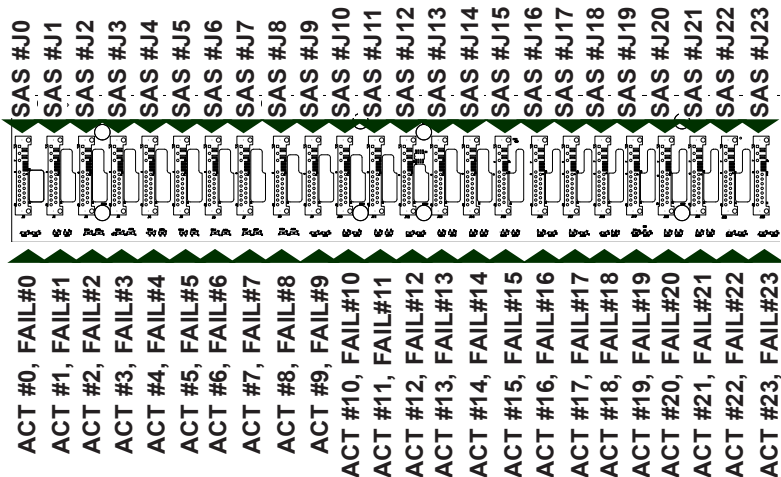

Figure C-5: Front Connectors and LEDs

Front SAS/SATA Connectors			
Front Connector	SAS Drive Number	Front Connector	SAS Drive Number
SAS #J0	SAS/SATA HDD #1	SAS #J12	SAS/SATA HDD #13
SAS #J1	SAS/SATA HDD #2	SAS #J13	SAS/SATA HDD #14
SAS #J2	SAS/SATA HDD #3	SAS #J14	SAS/SATA HDD #15
SAS #J3	SAS/SATA HDD #4	SAS #J15	SAS/SATA HDD #16
SAS #J4	SAS/SATA HDD #5	SAS #J16	SAS/SATA HDD #17
SAS #J5	SAS/SATA HDD #6	SAS #J17	SAS/SATA HDD #18
SAS #J6	SAS/SATA HDD #7	SAS #J18	SAS/SATA HDD #19
SAS #J7	SAS/SATA HDD #8	SAS #J19	SAS/SATA HDD #20
SAS #J8	SAS/SATA HDD #9	SAS #J20	SAS/SATA HDD #21
SAS #J9	SAS/SATA HDD #10	SAS #J21	SAS/SATA HDD #22
SAS #J10	SAS/SATA HDD #11	SAS #J22	SAS/SATA HDD #23
SAS #J11	SAS/SATA HDD #12	SAS #J23	SAS/SATA HDD #24

Front LED Indicators		
Front LED	Hard Drive Activity	Failure LED
SAS #J0	ACT #0	FAIL #0
SAS #J1	ACT #1	FAIL #1
SAS #J2	ACT #2	FAIL #2
SAS #J3	ACT #3	FAIL #3
SAS #J4	ACT #4	FAIL #4
SAS #J5	ACT #5	FAIL #5
SAS #J6	ACT #6	FAIL #6
SAS #J7	ACT #7	FAIL #7
SAS #J8	ACT #8	FAIL #8
SAS #J9	ACT #9	FAIL #9
SAS #J10	ACT #10	FAIL #10
SAS #J11	ACT #11	FAIL #11
SAS #J12	ACT #12	FAIL #12
SAS #J13	ACT #13	FAIL #13
SAS #J14	ACT #14	FAIL #14
SAS #J15	ACT #15	FAIL #15
SAS #J16	ACT #16	FAIL #16
SAS #J17	ACT #17	FAIL #17
SAS #J18	ACT #18	FAIL #18
SAS #J19	ACT #19	FAIL #19
SAS #J20	ACT #20	FAIL #20
SAS #J21	ACT #21	FAIL #21
SAS #J22	ACT #22	FAIL #22
SAS #J23	ACT #23	FAIL #23

Dual Port and Cascading Configurations

C-10 Single and Dual Port Expanders

Single Ports

SAS2-216EL1 model backplanes have a single-port expander on the daughter card that accesses all of the drives and supports cascading.

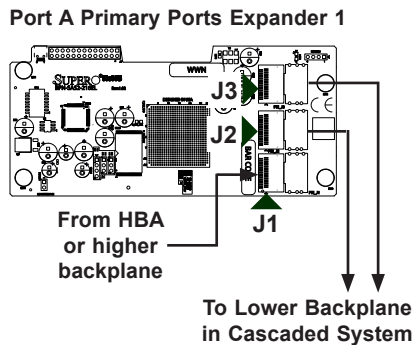

Figure C-6: SAS2-216EL1 Single Port Configuration

Dual Ports

SAS2-216EL2 model backplanes have dual-port expanders on the daughter cards that access all of the hard drives. These dual-port expanders support cascading, failover, and recovery.

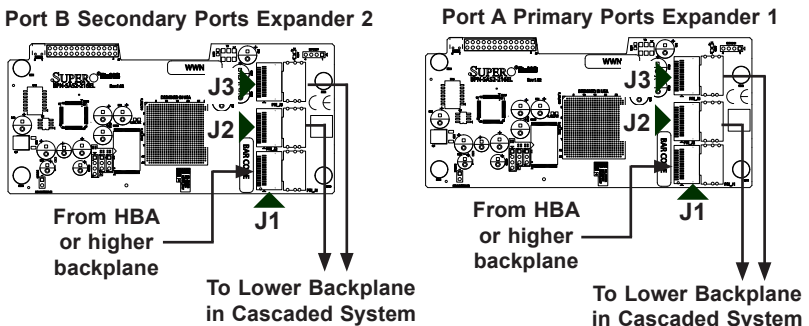

Figure C-7: SAS2-216EL2 Dual Port Configuration

C-11 Failover

The SAS2-216EL2 model backplane has two expanders which enable effective failover and recovery.

Single Host Bus Adapter

In a single host bus configuration, the backplane connects to one Host Bus Adapter (HBA).

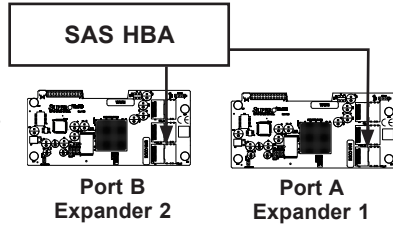

Figure C-8: Single HBA

Single Host Bus Adapter Failover

If the expander or data path in Port A fails, the system automatically switches to Port B.

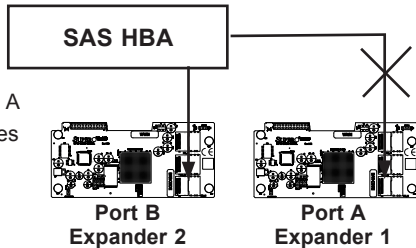

Figure C-9: Single HBA Failover

C-12 Failover with RAID Cards and Multiple HBAs

The SAS2-216EL backplane may be configured for failover with multiple HBAs using either RAID controllers or HBAs to achieve failover protection.

RAID Controllers: If RAID controllers are used, then the failover is accomplished through port failover on the same RAID card.

HBAs: If multiple HBAs are used to achieve failover protection and load balancing, **Linux MPIO software must be installed and correctly configured to perform the load balancing and failover tasks.**

Dual Host Bus Adapter

In a Dual Host Bus Configuration, the backplane connects to two Host Bus Adapters (HBA).

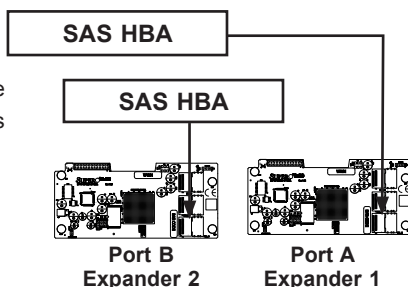

Figure C-9: Dual HBA

Dual Host Bus Adapter Failover

If the Expander or data path in Port A fails, the system automatically switches to Port B. This maintains a full connection to all drives.

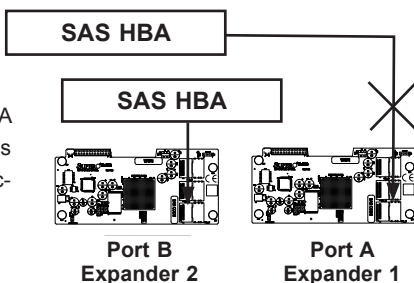

Figure C-10: Dual HBA Failover



IMPORTANT: For RAID controllers, redundancy is achieved through port failover. For multiple HBAs MPIO software is required to achieve failover protection.

C-13 Chassis Power Card and Support Cables

Chassis Power Card

In a cascaded configuration, the first chassis includes a motherboard and at least one Host Bus Adapter (HBA). Other servers in this enclosed system must be equipped with a power card. This section describes the supported power card for the SAS2-216EL series backplane.

For more information, see the Supermicro Web site at <http://www.supermicro.com>.

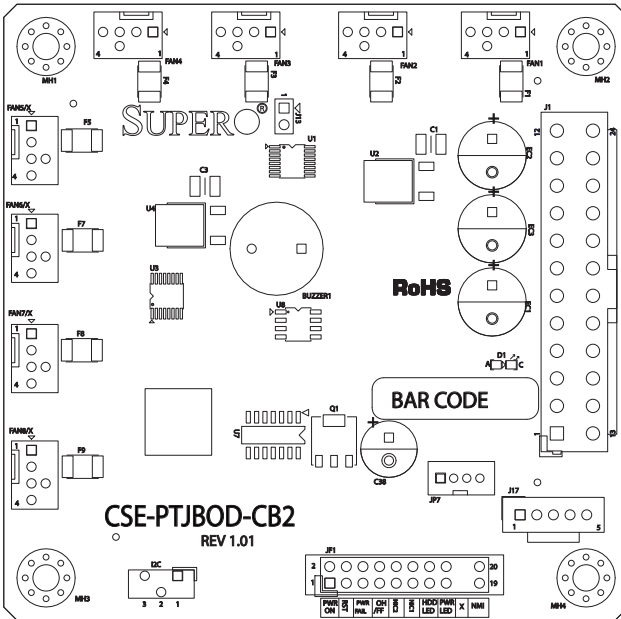

Figure C-11: Chassis Power Card (Sold Separately)

Power Card		
Part Number	Part Type	Where Used
CSE-PTJBOD-CB2	Power Card	Allows the chassis to be used as a JBOD (Just a Bunch of Drives) system.

Connecting an Internal HBA to the Backplane

The following section lists the most common cables used to connect the HBA to the backplane.

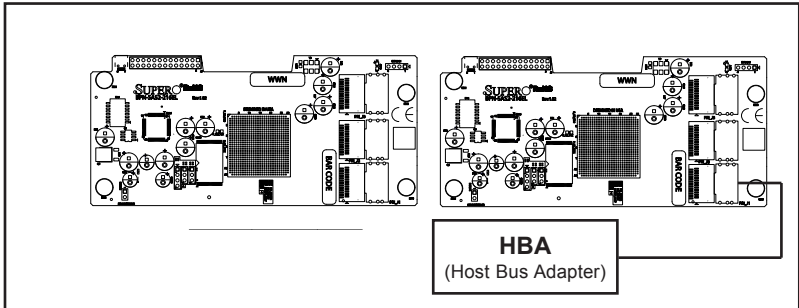

Figure C-12: Single Internal Host Bus Adapter

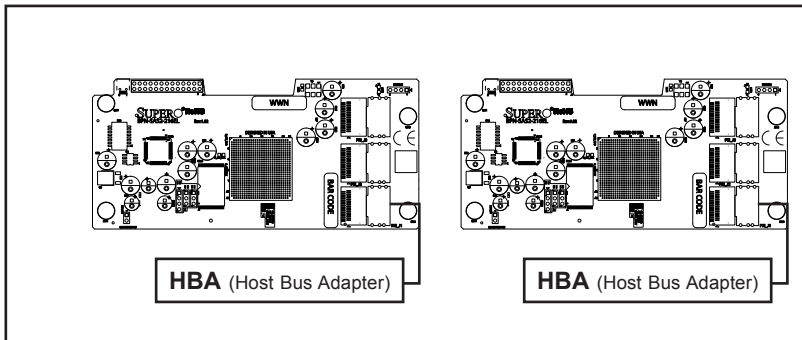

Figure C-13: Dual Internal Host Bus Adapter

Supported Internal HBA Cables

Use the following cables to create connections between the internal HBA and SAS2-216EL model backplane. The cables required depend upon the HBA connector.

Cable Name: iPass TO 4-LANE

Part #: CBL-0117L

Length: 46 cm (18 inches)

Description: This cable has one SFF-8484 (32-pin) connector at one end and one iPass (SFF-8087/Mini-SAS) connector (36-pin) at the other. This cable connects from the HBA to the SAS2-216EL backplane

IMPORTANT: See Section C-12 of this manual, *Failover with RAID Cards and Multiple HBAs* for important information on supported configurations.

Cable Name: iPass (Mini-SAS) to iPass (Mini-SAS)

Part #: CBL-0108L-02 **Length:** 39 cm (15 inches)

Part #: CBL-0109L-02 **Length:** 22 cm (9 inches)

Part #: CBL-0110L-02 **Length:** 18 cm (7 inches)

Description: This cable has an iPass (SFF-8087/Mini-SAS) connector (36-pin) at each end. It connects from the HBA to the SAS2-216EL model backplane.

Connecting an External HBA to the Backplane

This backplane supports external host bus adapters. In this configuration, the HBA and the backplane are in different physical chassis. This allows a JBOD (Just a Bunch Of Drives) configuration from an existing system.

Single External Host Bus Adapter

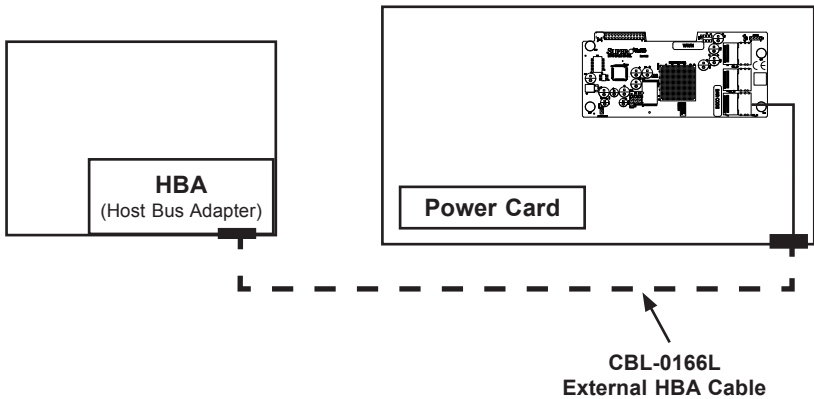

Figure C-14: Single External Host Adapter

Dual External Host Bus Adapter

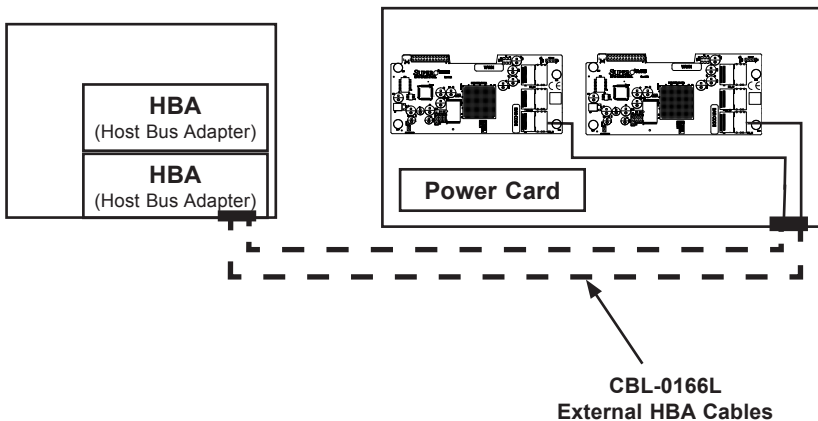

Figure C-15: Dual External Host Bus Adapter

IMPORTANT: See Section C-12 of this manual, *Failover with RAID Cards and Multiple HBAs* for important information on supported configurations.

Supported External HBA to Backplane Cable

Use the following cable if your external HBA has an InfiniBand connector.



Figure C-15: SAS InfiniBand Cable (CBL-0200L)

Cable Name: SAS InfiniBand to Mini-SAS X4 1M cable, PBF

Part #: CBL-0200L

Length: 1 meter

Description: This cable has an InfiniBand connector (SFF-8470) on one end and an SFF-8088-1X (26-pin) connector at the other end.

Connecting Multiple Backplanes in a Single Channel Environment

This section describes the cables used when cascading from a single HBA. These connections use CBL-0167L internal cables and CBL-0166L external cables.

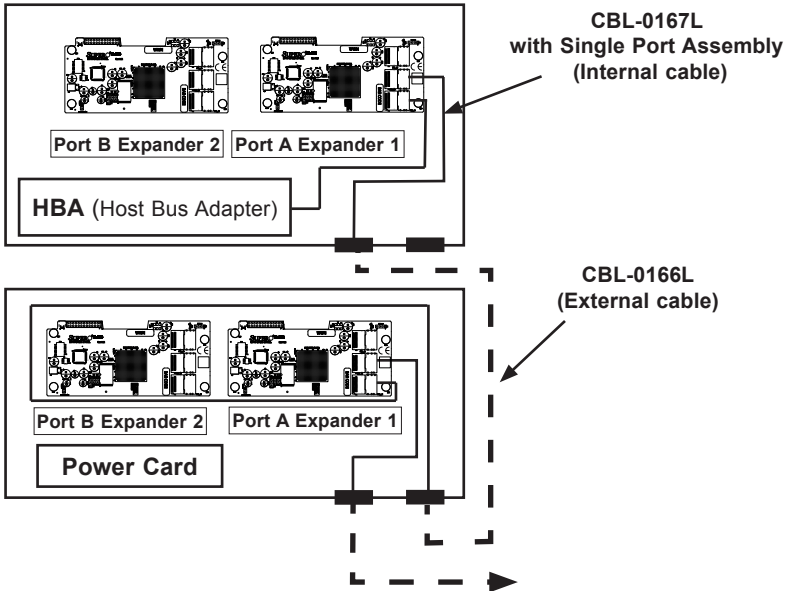

Figure C-16: Single HBA Configuration

Single HBA Configuration Cables

Single Port Cable Assembly

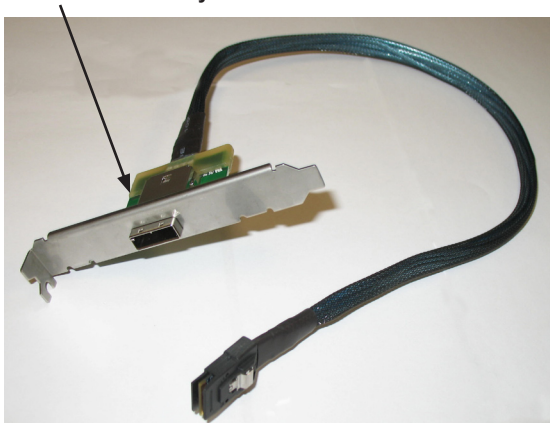

Figure C-17: Single Port Internal Cable (CBL-0167L)

Cable Name: SAS EL2/EL1 Backplane Cable (Internal) with 2-port Cascading Cable, 68 cm

Part #: CBL-0167L (SFF-8087 to SFF-8088 x1)

Ports: Single

Placement: Internal cable

Description: Internal cable. Connects the backplane to the HBA or external port. Used in single port environments



Figure C-18: External Cable (CBL-0166L)

Cable Name: SAS EL2/EL1 Cascading Cable (External), 68 cm

Part #: CBL-0166L (SFF-8088 1x to SFF-8088 x1)

Ports: Single or Dual

Placement: External cable

Description: External cascading cable. Connects ports between servers. With most connectors, use one cable for single port connections and two cables for dual port connections.

Connecting Multiple Backplanes in a Dual Channel Environment

This section describes the cables used when cascading from dual HBAs. These connections use CBL-0168L internal cables and CBL-0166L external cables.

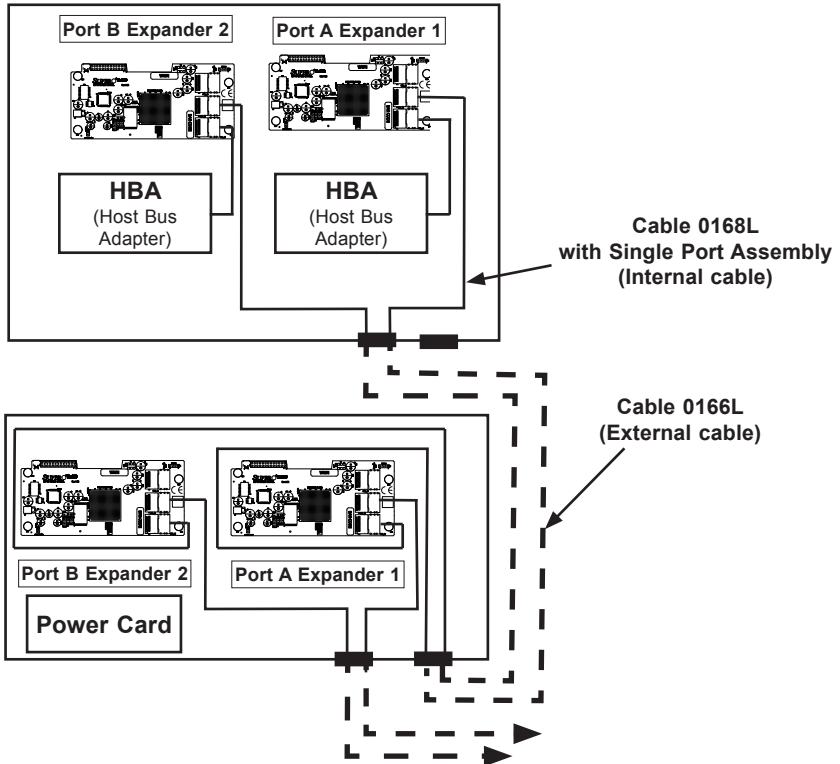

Figure C-19: Dual HBA Configuration

IMPORTANT: See Section C-12 of this manual, *Failover with RAID Cards and Multiple HBAs* for important information on supported configurations.

Dual HBA Configuration Cables

Dual Port Cable
Assembly



Figure C-20: Dual Port Internal Cable (CBL-0168L)

Cable Name: SAS Dual-port Cable Assembly, 68/76 cm

Part #: CBL-0168L

Placement: Internal cable

Ports: Dual

Description: Internal cascading cable. Connects the backplane to the host bus adapter or external port. Used in dual port environments.



Figure C-21: External Cable (CBL-0166L)

Cable Name: SAS EL2/EL1 Cascading Cable (External), 68 cm

Part #: CBL-0166L

Placement: External Cable

Ports: Single or Dual

Description: External cascading cable. Connects ports between servers. Use one cable for single port connections and two cables for dual port connections.

C-14 Supported Cascading Configurations

Cascading allows the system to access data at a faster rate by allowing several backplanes to share resources to reduce latency time.

The first backplane in a cascaded system requires a motherboard and an HBA. Other servers require a power control card with no motherboard and no HBA. For more information, specific chassis manuals are available at www.supermicro.com.

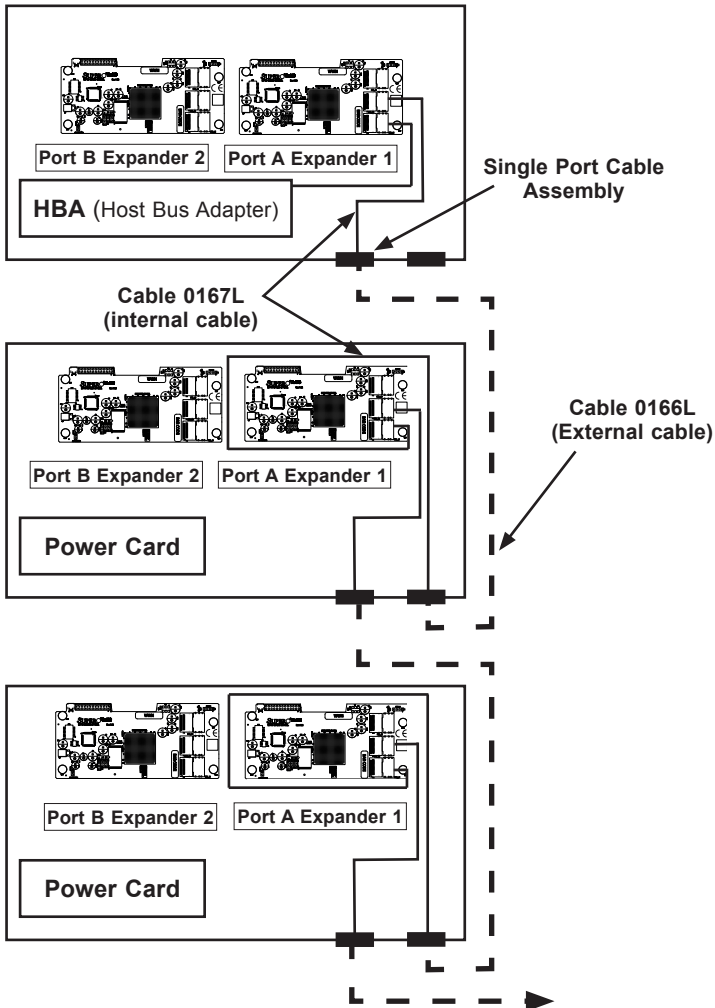

Figure C-22: Simple Cascaded Configuration

Server System with Single SAS HBA

The expanders allow horizontal branching. This configuration also applies to dual ports.

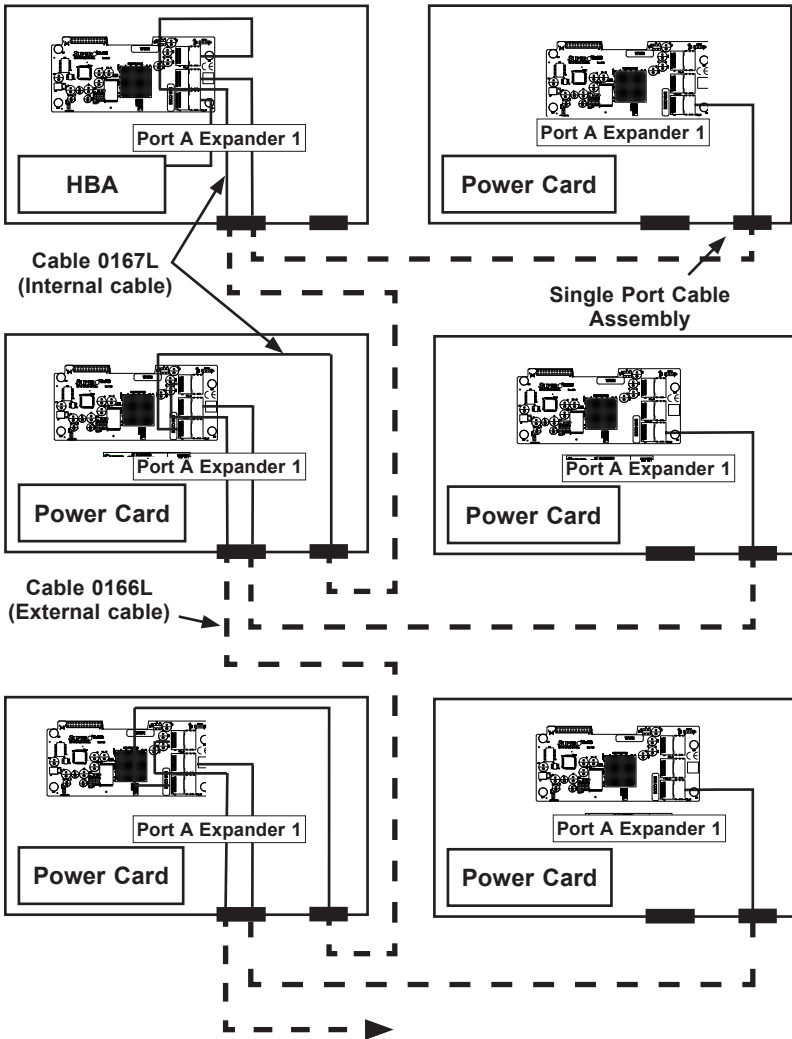

Figure C-23: Cascaded Configuration with Horizontal Branching

Dual SAS HBA and Cascaded Configuration

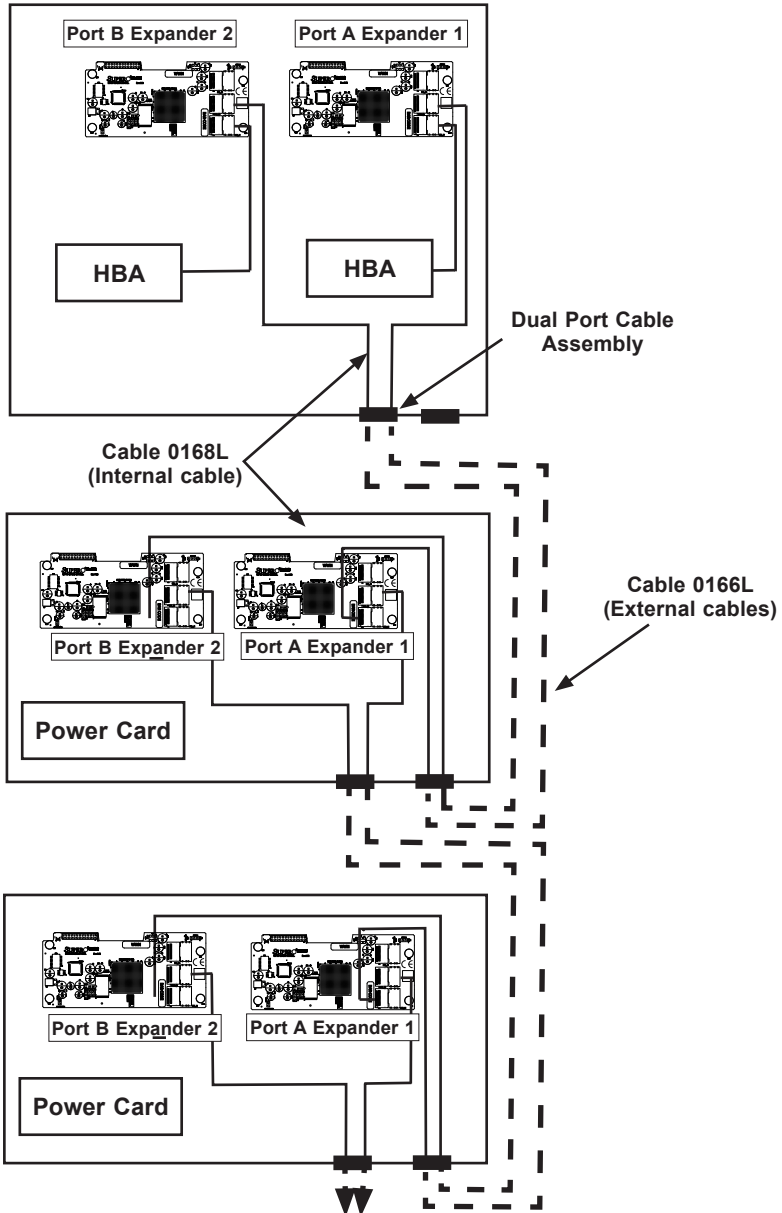

Figure C-24: Dual SAS HBA with Cascaded Configuration

IMPORTANT: See Section 3-3 of this manual, *Failover with RAID Cards and Multiple HBAs* for important information on supported configurations.

Dual SAS HBA and Cascaded Configuration with Branching

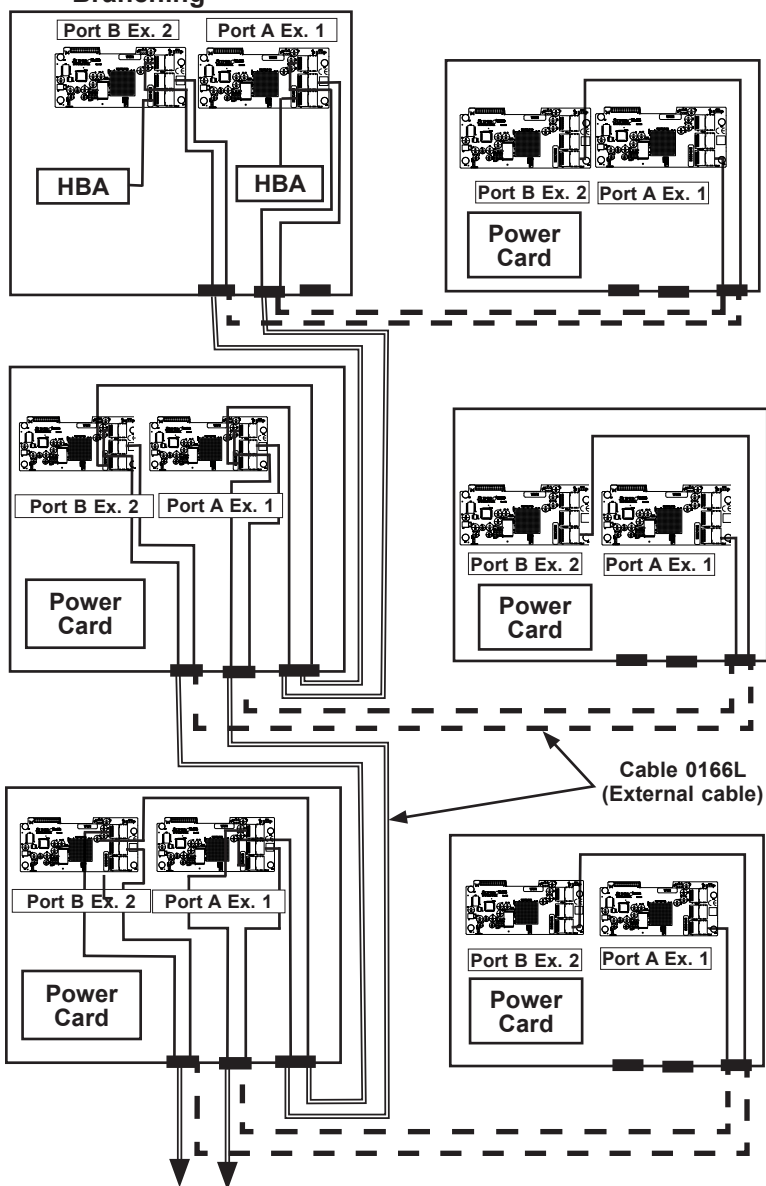

Figure C-25: Dual SAS HBA Cascaded Configuration and Branching

IMPORTANT: See Section 3-3 of this manual, *Failover with RAID Cards and Multiple HBAs* for important information on supported configurations.

Notes

Disclaimer (cont.)

The products sold by Supermicro are not intended for and will not be used in life support systems, medical equipment, nuclear facilities or systems, aircraft, aircraft devices, aircraft/emergency communication devices or other critical systems whose failure to perform be reasonably expected to result in significant injury or loss of life or catastrophic property damage. Accordingly, Supermicro disclaims any and all liability, and should buyer use or sell such products for use in such ultra-hazardous applications, it does so entirely at its own risk. Furthermore, buyer agrees to fully indemnify, defend and hold Supermicro harmless for and against any and all claims, demands, actions, litigation, and proceedings of any kind arising out of or related to such ultra-hazardous use or sale.