

SUPER[®]

CPU/Heatsink Installation and Removal

USER'S GUIDE

Revision 1.0a

The information in this USER'S GUIDE has been carefully reviewed and is believed to be accurate. The vendor assumes no responsibility for any inaccuracies that may be contained in this document, makes no commitment to update or to keep current the information in this manual, or to notify any person or organization of the updates. **Please Note: For the most up-to-date version of this manual, please see our web site at www.supermicro.com.**

Super Micro Computer, Inc. ("Supermicro") reserves the right to make changes to the product described in this manual at any time and without notice. This product, including software and documentation, is the property of Supermicro and/or its licensors, and is supplied only under a license. Any use or reproduction of this product is not allowed, except as expressly permitted by the terms of said license.

IN NO EVENT WILL SUPERMICRO BE LIABLE FOR DIRECT, INDIRECT, SPECIAL, INCIDENTAL, SPECULATIVE OR CONSEQUENTIAL DAMAGES ARISING FROM THE USE OR INABILITY TO USE THIS DOCUMENTATION, EVEN IF ADVISED OF THE POSSIBILITY OF SUCH DAMAGES.

Any disputes arising between Supermicro and customer shall be governed by the laws of Santa Clara County in the State of California, USA. The State of California, County of Santa Clara shall be the exclusive venue for the resolution of any such disputes. Super Micro's total liability for all claims will not exceed the price paid for the hardware product.

WARNING: Handling of lead solder materials used in the product mentioned in this document may expose you to lead, a chemical known to the State of California to cause birth defects and other reproductive harm.

Manual Revision: Rev. 1.0a

Release Date: Feb. 25, 2011

Unless you request and receive written permission from Super Micro Computer, Inc., you may not copy any part of this document.

Information in this document is subject to change without notice. Other products and companies referred to herein are trademarks or registered trademarks of their respective companies or mark holders.

Copyright © 2011 by Super Micro Computer, Inc.
All rights reserved.

Printed in the United States of America

Preface

This User's Guide is written for system integrators, PC technicians and knowledgeable PC users. It provides detailed instructions on CPU/Heatsink installation and removal.

About This User's Guide

The CPU/Heatsink Installation and Removal User's Guide provides detailed instructions on how to properly install and remove an Intel processor and a heatsink on a motherboard. It also provides detailed instructions on how to avoid damaging the processors, CPU sockets and other CPU-related components. Please refer to our website (<http://www.supermicro.com/products/>) for updates on Intel processor support.

Manual Organization

Chapter 1 describes common mistakes that will cause damage to the CPU or related components and how to avoid them.

Chapter 2 provides CPU and heatsink installation instructions to ensure proper CPU and heatsink installation.

Chapter 3 provides detailed instructions on how to properly remove the processor and the heatsink from the system.

Conventions Used in the Manual

Special attention should be given to the following symbols for proper installation and to prevent product damage.

 **Warning:** Important information given to ensure proper installation or to avoid damage to the components.

 **Note:** Additional Information given to differentiate between various models or to ensure correct system setup.

Contacting Supermicro

Headquarters

Address: Super Micro Computer, Inc.
980 Rock Ave.
San Jose, CA 95131 U.S.A.

Tel: +1 (408) 503-8000

Fax: +1 (408) 503-8008

Email: marketing@supermicro.com (General Information)
support@supermicro.com (Technical Support)

Web Site: www.supermicro.com

Europe

Address: Super Micro Computer B.V.
Het Sterrenbeeld 28, 5215 ML
's-Hertogenbosch, The Netherlands

Tel: +31 (0) 73-6400390

Fax: +31 (0) 73-6416525

Email: sales@supermicro.nl (General Information)
support@supermicro.nl (Technical Support)
rma@supermicro.nl (Customer Support)

Asia-Pacific

Address: Super Micro Computer, Inc.
4F, No. 232-1, Liancheng Rd.
Chung-Ho 235, Taipei County
Taiwan, R.O.C.

Tel: +886-(2) 8226-3990

Fax: +886-(2) 8226-3991

Web Site: www.supermicro.com.tw

Technical Support:
Email: support@supermicro.com.tw

Tel: 886-2-8228-1366, ext.132 or 139

Table of Contents

Chapter 1 Avoiding Common Causes of CPU-Related Damage

1-1	CPU and CPU-Related Components.....	1-1
1-2	Common Causes	1-3
	Cause No. 1: Direct Contact with the CPU and its Components.....	1-4
	Cause No. 2: Indirect Contact with the CPU and its Components	1-4
	Cause No. 3: Accidental Contact during Installation or Removal.....	1-5
	Cause No. 4: Other Causes.....	1-5

Chapter 2 CPU and Heatsink Installation

2-1	Preparing for CPU Installation	2-1
2-2	Installing the CPU	2-4
	Opening the Load Plate.....	2-4
2.3	CPU Heatsink/Fan Installation	2-10
	Installing a Passive Heatsink	2-10
	Installing an Active Heatsink Fan.....	2-11

Chapter 3 CPU and Heatsink Removal

3-1	Heatsink Removal	3-1
	Removing a Passive Heatsink	3-1
	Removing an Active Heatsink	3-2
3-2	CPU Removal	3-3
	Opening the Load Plate.....	3-3
	Removing the CPU from the CPU Socket.....	3-4
	Placing the Plastic Cap on the CPU Socket.....	3-5

Chapter 1

Avoiding Common Causes of CPU-Related Damage

1-1 CPU and CPU-Related Components

Before installing the CPU on your motherboard, it is imperative that you familiarize yourself with the CPU, CPU socket and other CPU-related components.

CPU and its Components

1. CPU
2. CPU Key
3. CPU Pin 1
4. CPU Pins
5. CPU Frame/Heat Spreader

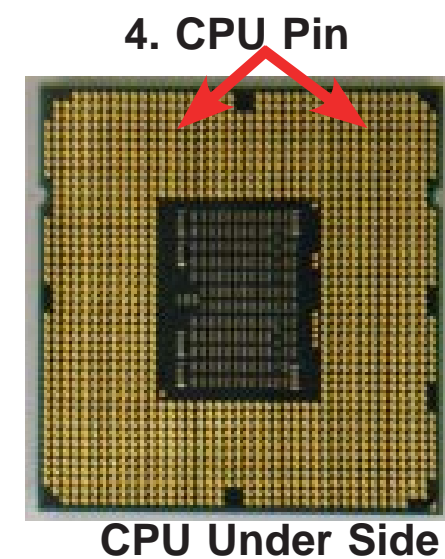
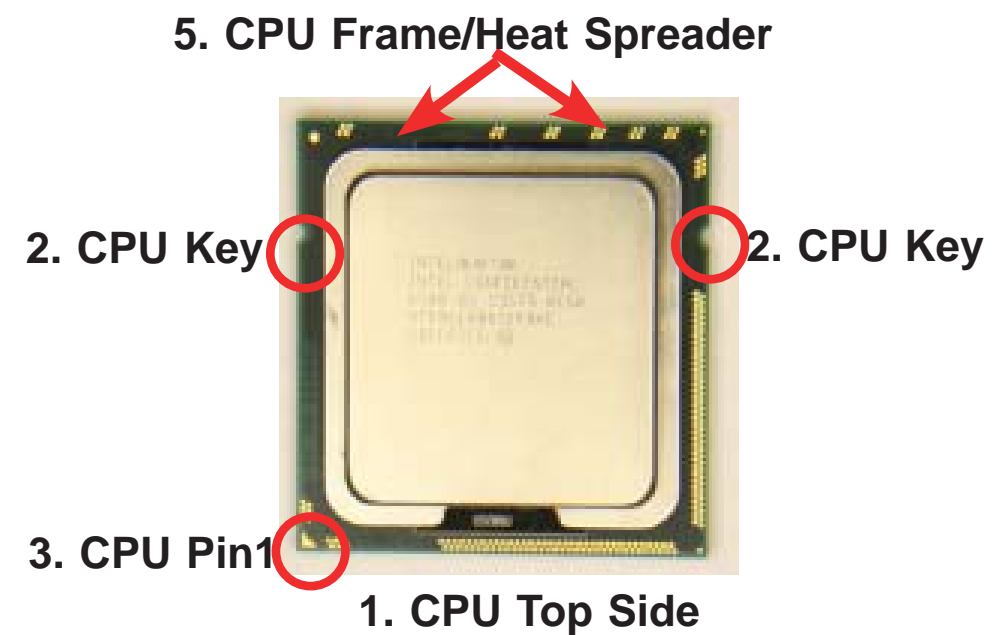

CPU Plastic Cap and its Parts

1. Cap Pin 1
2. Cap Keys



CPU Socket and its Components

3. CPU Socket
4. Socket Keys
5. LGA Contact
6. Socket Pin 1
7. Socket Clip
8. Clip Latch
9. North Center Edge of the CPU Socket
10. South Center Edge of the CPU Socket

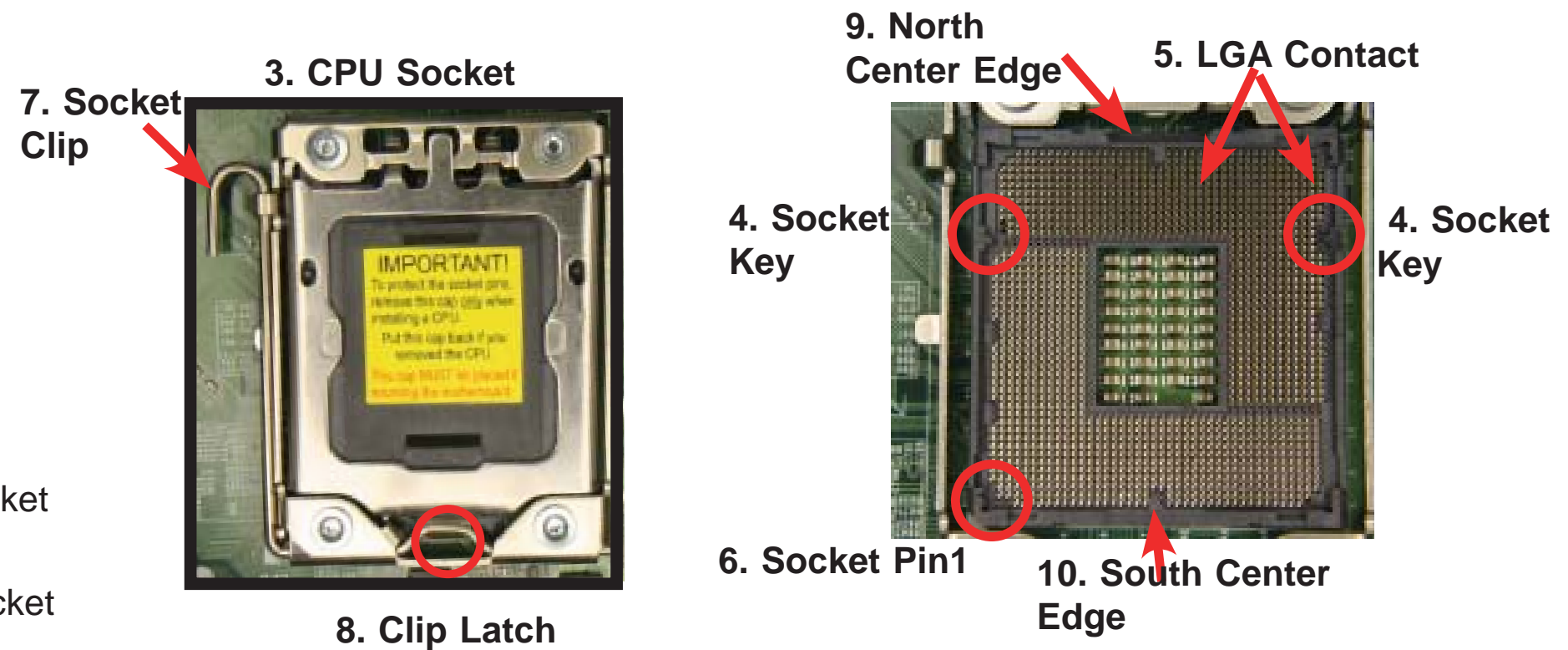

Load Plate and its Parts

1. Load Plate Tab
2. Load Plate Tip

2. Load Plate Tip



1. Load Plate Tab

1-2 Common Causes

This section describes common mistakes that will cause damage to the CPU, its pins, its socket or other components.

Warning!!

- Be sure to wear finger gloves when handling the CPU or components to avoid damaging them.
- Bent pins may result in short circuits or cause fire. Before installing a component on your motherboard, be sure to carefully inspect the CPU, the socket and the motherboard for bent pins. If you find any bent pins, do not continue with component installation.

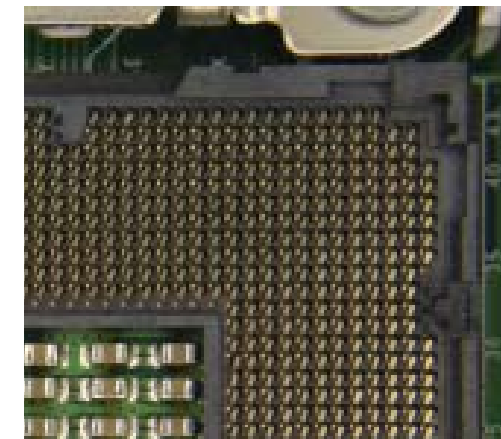

Inspect CPU socket for bent pins

Cause No. 1: Direct Contact with the CPU and its Components

1. Do not touch the CPU, its pins, its socket or other CPU-related components without finger grooves.
2. Do not use excessive force or place direct pressure on the CPU, its surface, pins, CPU socket or other CPU-related components.
3. If a load plate is damaged or if its surface becomes uneven, do not lock the load plate into the locked position which will cause further damage to the CPU or the CPU socket.

Cause No. 2: Indirect Contact with the CPU and its Components

4. Do not make any indirect contact with the CPU, CPU pins, CPU socket or any components through your gloves, your pen, your tools or items such as cell phones, pens, necklaces, gloves or rings.
5. Hold the CPU securely; do not drop it on the ground, on the CPU socket or on other surface to avoid bending the CPU/socket pins or making scratches on any components. Do not drop any tools, any objects or equipment on the CPU or the socket.

1. Do not touch the CPU
2. Do not use excessive force

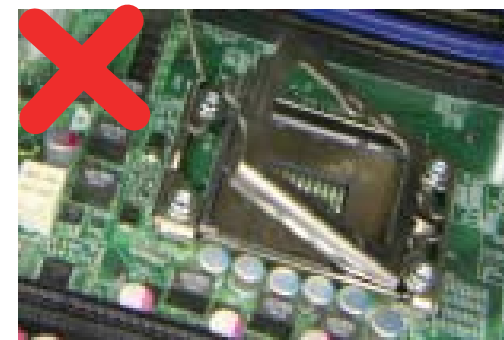
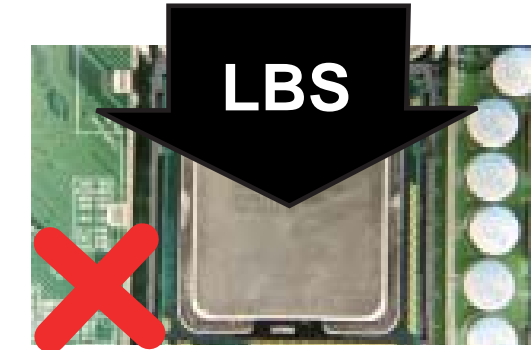
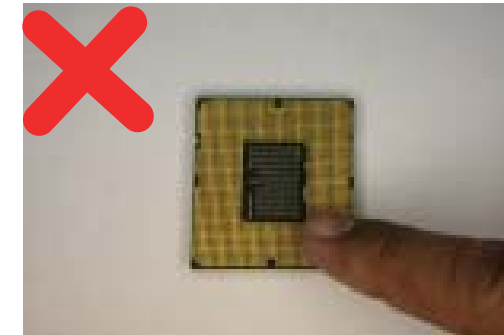

3. Do not use damaged socket.

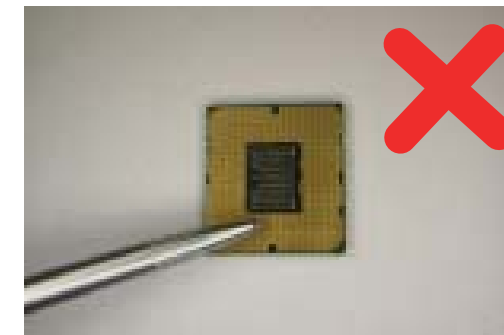

4. Do not make indirect contact with the CPU.



5. Hold the CPU securely.

Cause No. 3: Accidental Contact during Installation or Removal

6. When installing or removing the CPU on the motherboard, hold the CPU at the center edges and insert it straight down into the CPU socket. Be sure to wear finger gloves when holding the CPU. Do not tilt the CPU at an angle to prevent it from making contact with the socket or rubbing the CPU pins against the CPU socket or the socket pins.
7. Handle the CPU properly to avoid the corner of the CPU or the CPU pins from making contact with the CPU socket when installing or removing the CPU to avoid bending the CPU pins or socket pins.



6. Holding the center edges of the CPU, insert it straight down into the socket.

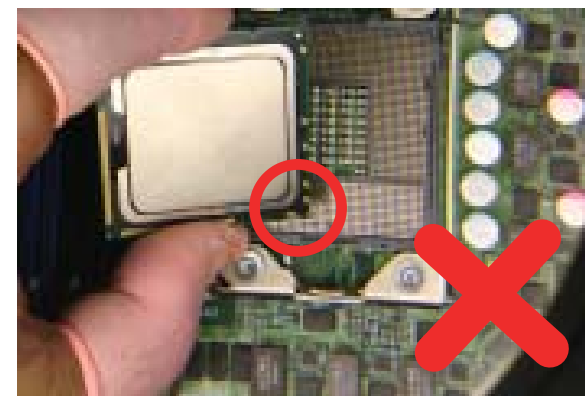

7. Do not tilt the CPU at an angle.

Cause No. 4: Other Causes

8. Misalignment: Make sure to align the CPU keys with the socket keys to avoid damage caused by CPU misalignment. Also make sure that the CPU is fully and properly seated in the socket.

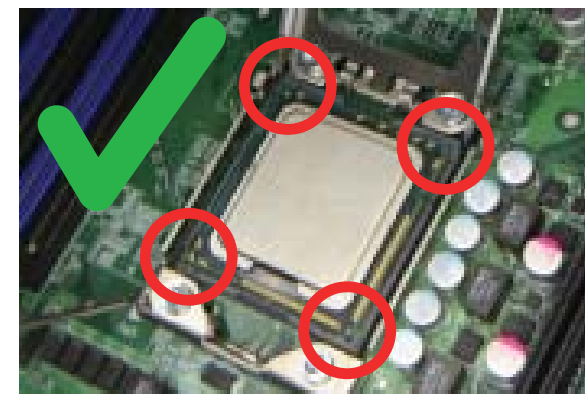

8. Align the CPU keys with the socket keys.

9. ESD: Use a grounded wrist strap designed to prevent static discharge when handling the CPUs and CPU-related components.
10. Excessive amount of thermal grease applied: Apply only the right amount of thermal grease on the CPU to prevent any excess from spilling over on the CPU socket.
11. Scratches caused by cleaning: Be cautious when cleaning the residue of the thermal grease from the CPU socket. Do not use sharp tools which may scratch the CPU or the socket. Do not allow the cleaning agent or cleaning pad/cloth to make contact with the socket pins.
12. Installing the CPU into a damaged socket: Do not install the CPU into a damaged CPU socket which may further damage the CPU socket or the motherboard due to the uneven surface. Please note that an uneven surface or bent pins may result in short circuits or cause fire. In this case, do not proceed with CPU or heatsink installation.
13. Forcing a damaged load plate into the locked position: Do not force a damaged CPU load plate into the locked position which may further damage the CPU pins.

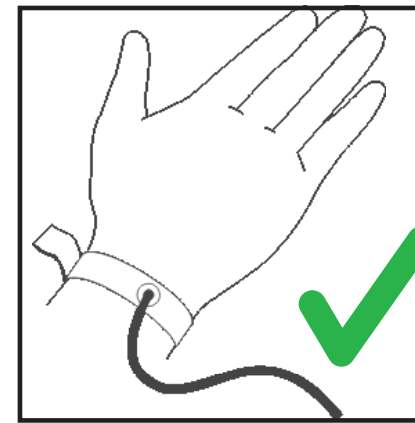

9. Avoid ESD Damage.

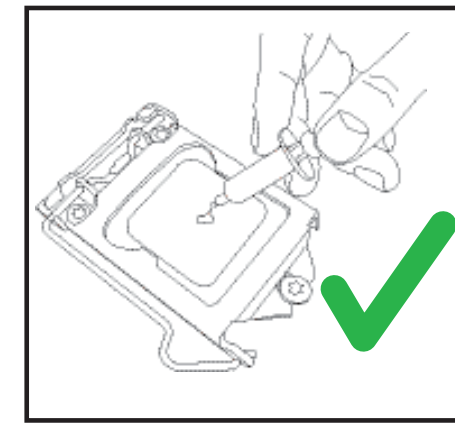

10. Use the right amount of thermal grease.

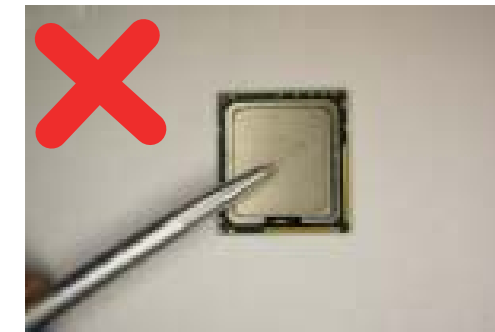

11. Do not use sharp tools for cleaning.

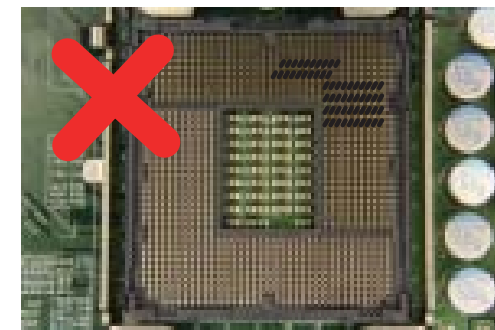

12. Do not use a damaged socket.

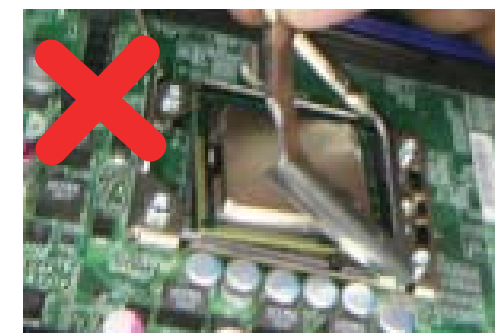

13. Do not lock a damaged load plate.

14. Improper CPU installation and removal: Be sure to follow the instructions given in Chapter 2 and Chapter 3 for proper CPU/heatsink installation and removal. Improper CPU installation and removal will cause damage to the CPU and the CPU-related components.

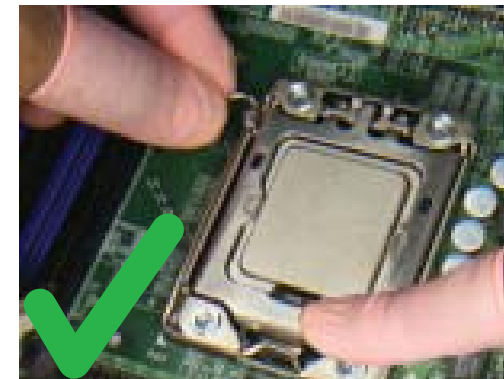

14. Install and remove the CPU properly.

15. Fabric in a glove made of cloth or a finger glove of the wrong size may bend the CPU or socket pins.



15. Do not use fabric gloves.

16. Greasy or dirty hands may leave grease/oil or foreign particles such as dust on the surface of a component.



16. Do not use dirty hands.

17. Long nails can scratch the surface of a component or bend a pin when making contact with a component.

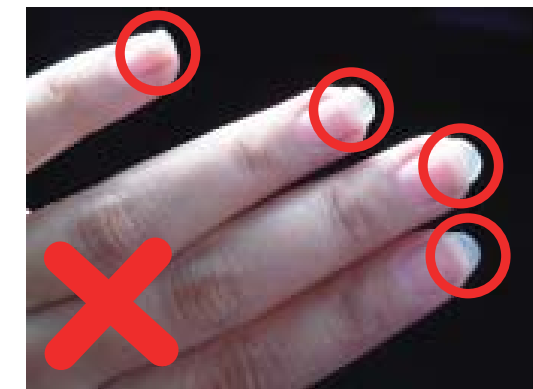

17. Watch out for long nails.

18. Holding a CPU or its components with bare hands may cause damage from ESD.

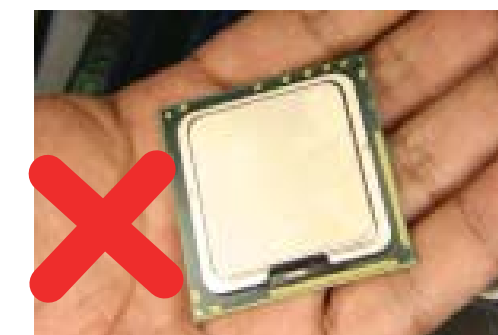

18. Do not hold the CPU using bare hands.

Notes

Chapter 2

CPU and Heatsink Installation

2-1 Preparing for CPU Installation

To install the CPU properly, please follow the instructions below before CPU installation.

Be Aware of Electrostatic Discharge (ESD)

Electrostatic Discharge (ESD) can damage electronic components. To avoid damaging your CPU or your system board, it is important to handle it very carefully. The following measures are generally sufficient to protect your equipment from ESD.

How to Avoid Damage Caused by ESD

1. Use a grounded wrist strap designed to prevent static discharge.
2. Touch a grounded metal object before removing components from the antistatic bag.

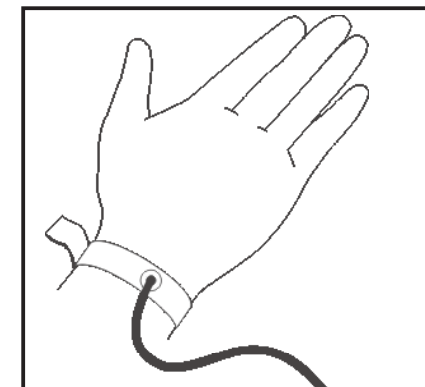

1. Use grounded wrist straps.



2. Touch grounded metal objects.

3. Follow the instructions listed in this user guide to properly handle the CPU and its components. Avoid touching the surface of a CPU, its pins, the socket and other components.
4. Put the CPU and the motherboard back into the antistatic bags when not in use.

Preparing the Work Area

1. Make sure to lay the motherboard on a level surface such as a work bench or work station.
2. Keep your work area neat and clean. Make sure that the work area is clog-free to prevent unneeded tools or objects from falling on the CPU, CPU pins, CPU socket or other CPU-related components.
3. Remove unneeded items or objects from you or your pockets to prevent them from falling onto the CPU or its components. Also make sure that personal items such as cell phones, watches or rings, will not scratch the CPU or CPU-related components.



3. Follow the instructions in the user guide.



4. Store the CPU/ motherboard in the antistatic bag.



1. Lay the motherboard on the level surface.



3. Remove unneeded items from your pocket.

 **Warning!**

1. Always connect the power cord last and always remove it before adding, removing or changing any hardware components. Make sure that you install the processor into the CPU socket before you install the CPU heatsink.
2. Make sure to install the motherboard into the chassis before you install the CPU heatsink and heatsink fans.
3. When purchasing a motherboard without an Intel processor pre-installed, make sure that the CPU socket plastic cap is in place, and none of the CPU socket pins are bent; otherwise, contact the retailer immediately.



1. **Connect the power supply before servicing your system.**

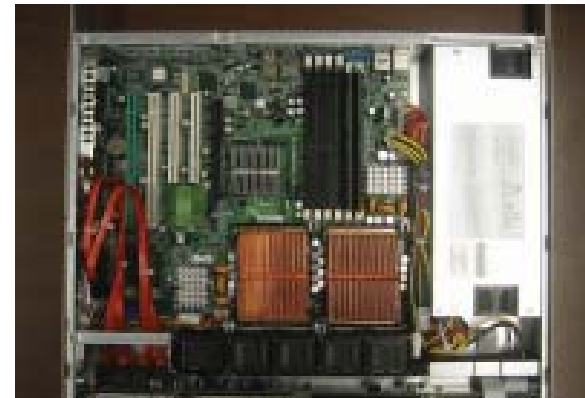

2. **Install the CPU/Heatsink after placing the motherboard in the chassis.**



3. **Upon receiving a CPU, make sure that the plastic cap is in place. Inspect for bent pins.**

2-2 Installing the CPU

After placing the motherboard on a level surface in a clean and neat work area, and removing all unneeded personal items, you are ready to install the CPU.



Warning!

When handling the processor package, avoid placing direct pressure on the label area of the fan.

Opening the Load Plate

1. Use one hand to secure the motherboard, and use the other hand to press the socket clip down to unlock the load plate, which covers the CPU socket.
2. Gently lift the socket clip upward to open the load plate.
3. Gently push the tab of the load plate to open the load plate.
4. Hold the plastic cap at its north and south center edges to pull it straight up from the CPU socket without moving it horizontally to prevent its corners from touching the socket pins.
5. Put the plastic cap in a secure place for safe-keeping.



1. **Secure the motherboard with one hand and use another to unlock the load plate.**



2. **Gently lift the socket clip.**



3. **Gently push the tab to open the load plate.**



4. **Hold the plastic cap at the center edges.**

 **Warning!**

- Do not tilt the plastic cap at an angle to prevent its edge from touching the CPU socket or brushing against the socket pins.
- Be sure to store the plastic cap in a secure place. The motherboard must be shipped with the plastic cap properly installed to protect the CPU socket pins. Shipping without the plastic cap properly installed will cause damage to the socket pins and void the manufacture warranty.

Inspecting the CPU, the CPU Socket, the Load Plate and Related Components

After the plastic cap has been removed and stored in a secure place, carefully inspect the CPU socket, socket pins and the load plate for damage.

1. Put the motherboard 6~12 inches away from you.
2. Carefully inspect the following items to make sure that they are in very good working condition and without any damage such as broken pins or bent pins. Also, make sure that there are no foreign objects present.

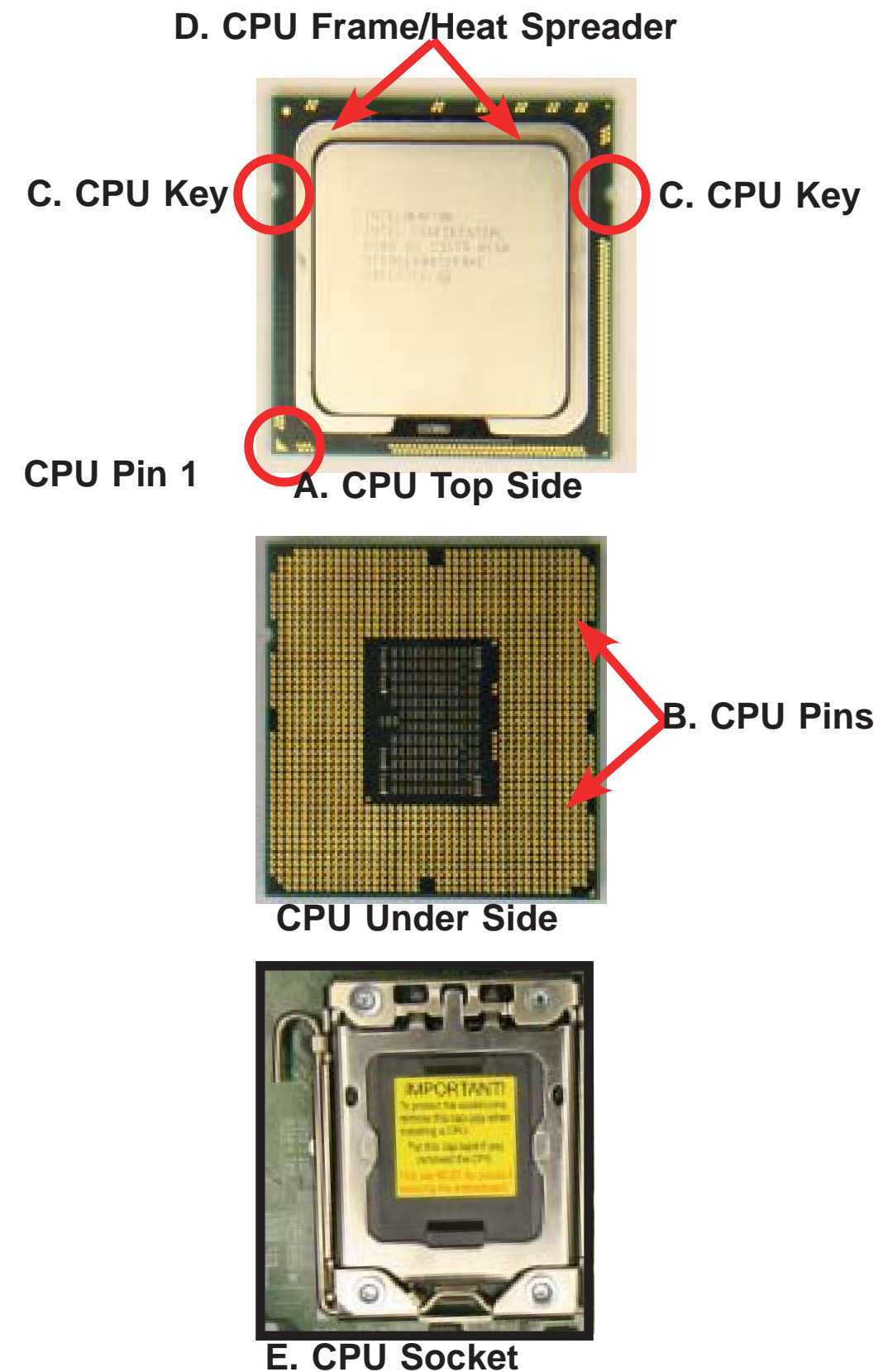

- A. CPU
 - B. CPU Pins
 - C. CPU Keys
 - D. CPU Frame and Heat Spreader
 - E. CPU Socket
 - F. Socket Pins
 - G. Four Corners of the Socket
 - H. Socket keys
3. Carefully inspect the load plate and its parts, using a magnifier lamp if possible, to make sure that they are not damaged in any way. Make sure that the surface is smooth and nothing is bent.
- I. Load Plate Tab
 - J. Load Plate Tip
 - K. Socket Clip Latch
 - L. Plastic Cap Pin 1

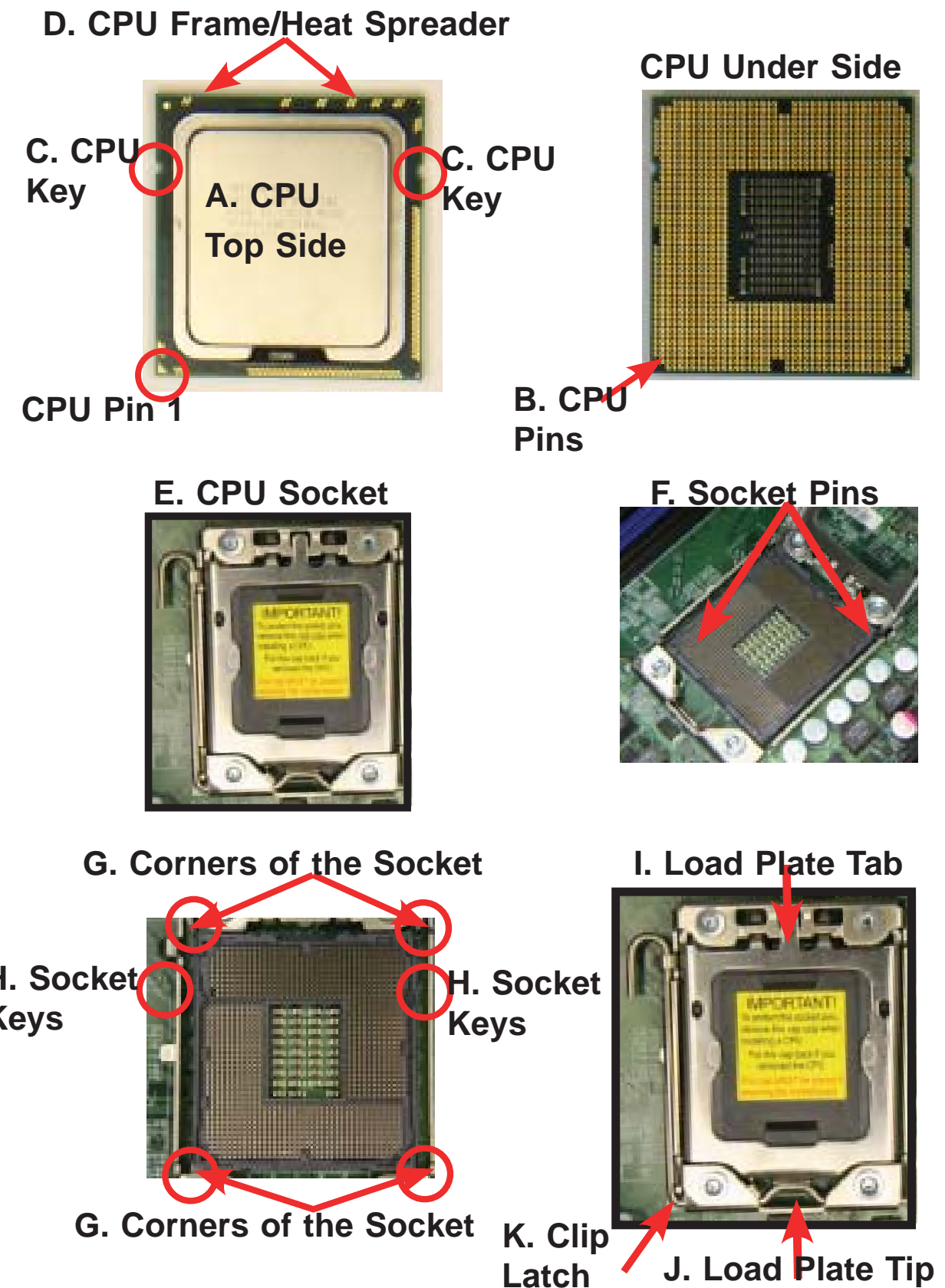

M. Plastic Cap Keys

N. Plastic Cap Center Edges

O. The Frame of the Plastic Cap

Inserting the CPU into the CPU Socket

Warning!

- Be sure to wear finger gloves before handling the CPU or components to avoid damaging them.
- Bent pins may result in short circuits or cause fire. Before installing a component on the motherboard, be sure to carefully inspect the CPU, the socket and the motherboard for bent pins. If you find any bent pins, do not continue with component installation

After you've inspected the CPU, CPU socket, load plate, and other components, making sure that every component is in good working condition, then you can insert the CPU into the socket.

1. Using your thumb and the index finger, hold the CPU at the north and south center edges.

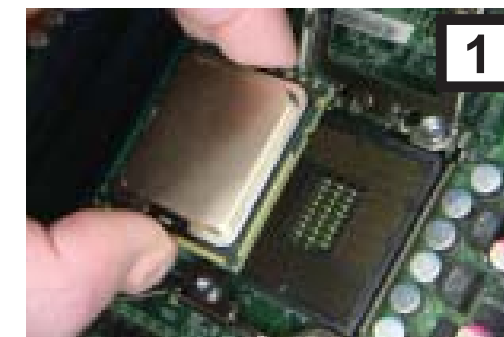
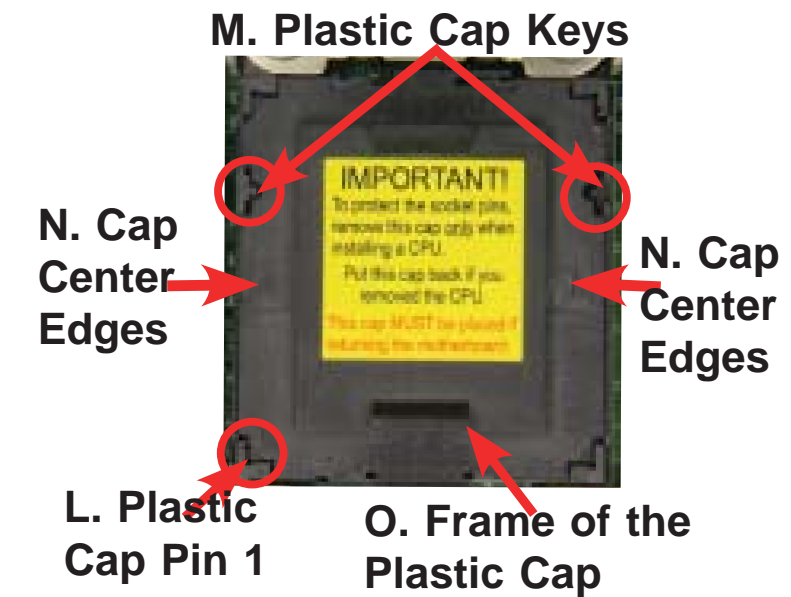

2. Locate Pin 1 of the CPU, which is marked with a gold triangle on the CPU. Locate Pin 1 of the socket, which is marked with a triangle on the socket or the motherboard.
3. Align Pin 1 of the CPU with Pin 1 of the CPU socket.
4. Locate the CPU keys, which are the semi-circle cutouts on the sides of CPU, and the socket keys, which are the notches on the sides of the socket.
5. Align the CPU keys with the socket keys.
6. Once both the CPU and the socket are aligned, carefully lower the CPU straight down into the socket. Do not rub the CPU against the surface of the socket or its pins to avoid damaging the CPU or the socket.
7. With the CPU in the socket, inspect the four corners of the CPU to make sure that the CPU is properly and fully seated in the CPU socket.

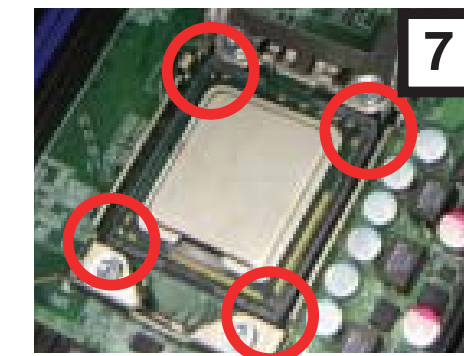
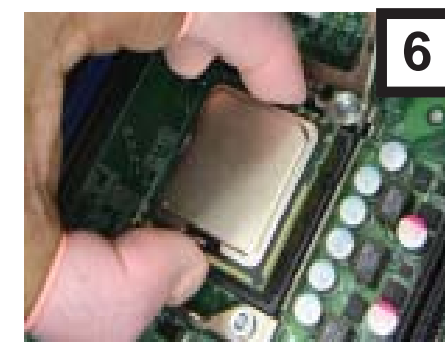
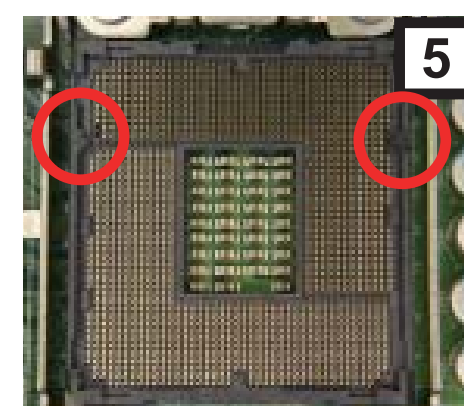
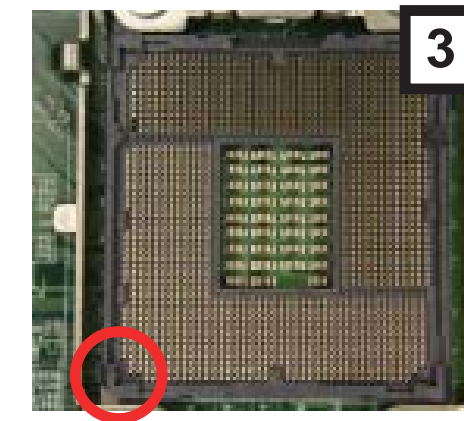

**Warning!**

Be sure to store the plastic cap in a secure place. The motherboard must be shipped with the plastic cap properly installed to protect the CPU socket pins. Shipping without the plastic cap properly installed will cause damage to the socket pins.

Securing the CPU to the CPU Socket with the Load Plate

1. Once the CPU is properly seated on the socket, gently lower the load plate down to the CPU.
2. With the load plate on top of the CPU, use the index finger of one hand to gently press it to secure it to the socket.
3. Using the thumb and the index finger of the other hand, pull the socket clip forward to engage the latch of the clip with the tip of the load plate.
4. Once the clip latch is on the top of the load plate, push the socket click down to lock it.

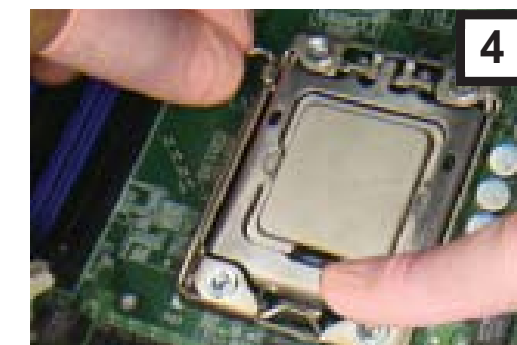
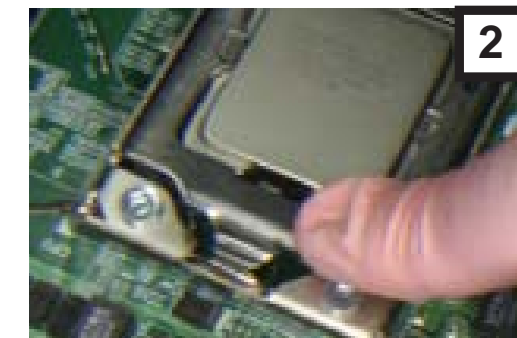
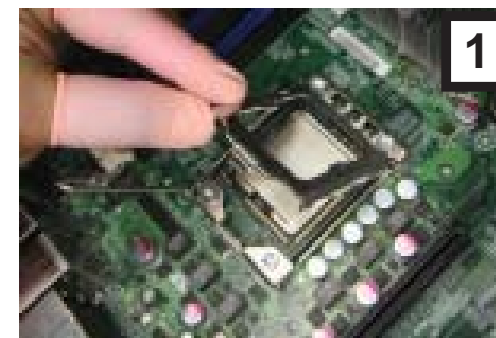

2.3 CPU Heatsink/Fan Installation

Installing a Passive Heatsink

1. Do not apply any thermal grease to the heatsink or the CPU die because the required amount has already been pre-applied.
2. Place the heatsink on top of the CPU so that the four mounting holes are aligned with those on the retention mechanism.
3. Install two diagonal screws (i.e. the #1 and the #2 screws) and tighten them until just snug (-do not fully tighten the screws to avoid possible damage to the CPU).
4. Finish the installation by fully tightening all four screws.

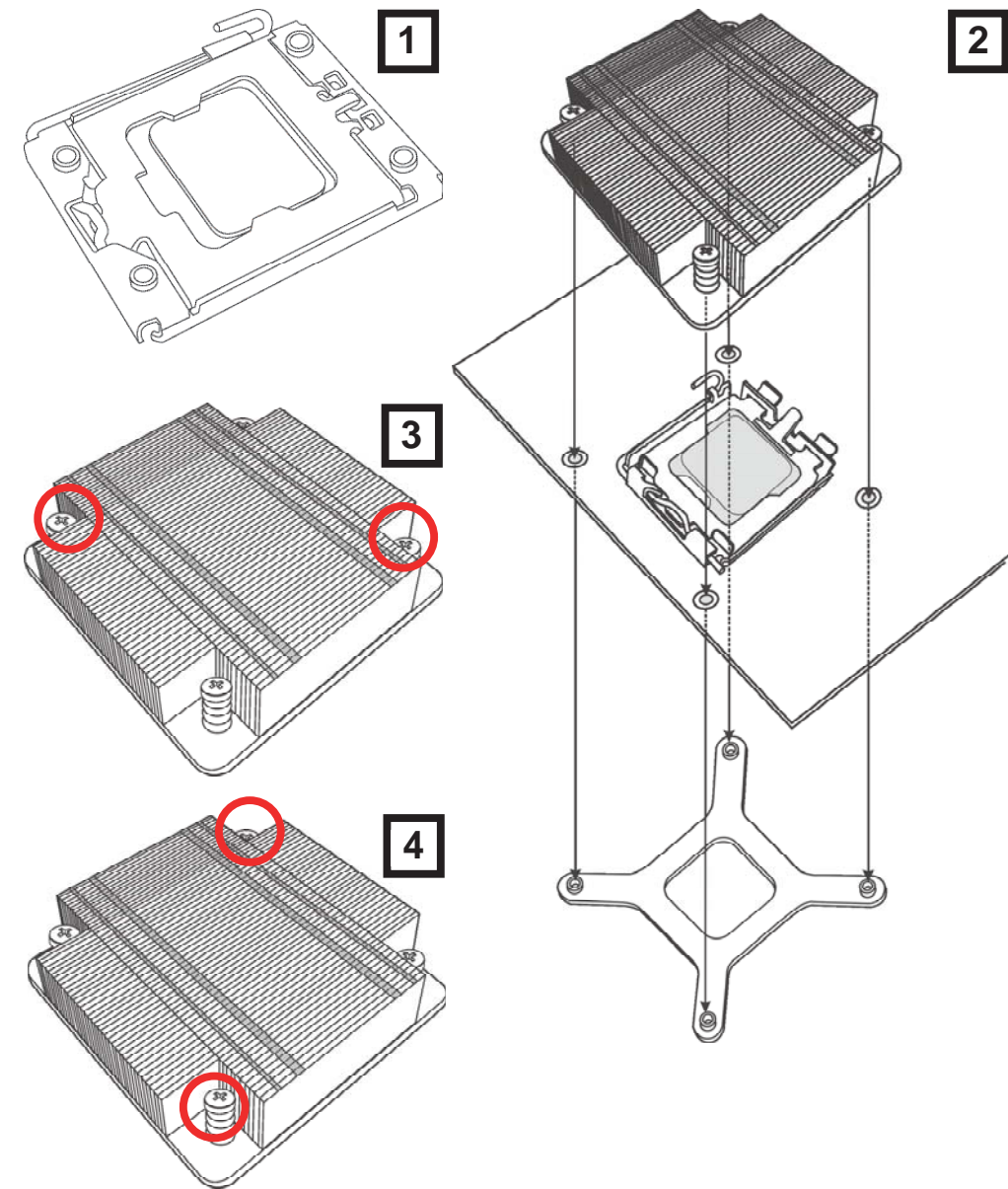

Installing an Active Heatsink Fan

1. Locate the CPU fan power connector on the motherboard.
2. Position the heatsink so that the heatsink fan wires are closest to the CPU fan power connector and do not interfere with other components.
3. Inspect the CPU Fan wires to make sure that the wires are routed through the bottom of the heatsink.
4. Remove the thin layer of protective film from the heatsink.

 **Warning:** CPU overheat may occur if the protective film is not removed from the heatsink.

5. Apply the proper amount of thermal grease on the CPU.

 **Note:** if your heatsink came with a thermal pad, please ignore this step.

6. If necessary, rearrange the wires to make sure that they are not pinched between the heatsink and the CPU. Also make sure to keep clearance between the fan wires and the fins of the heatsink.

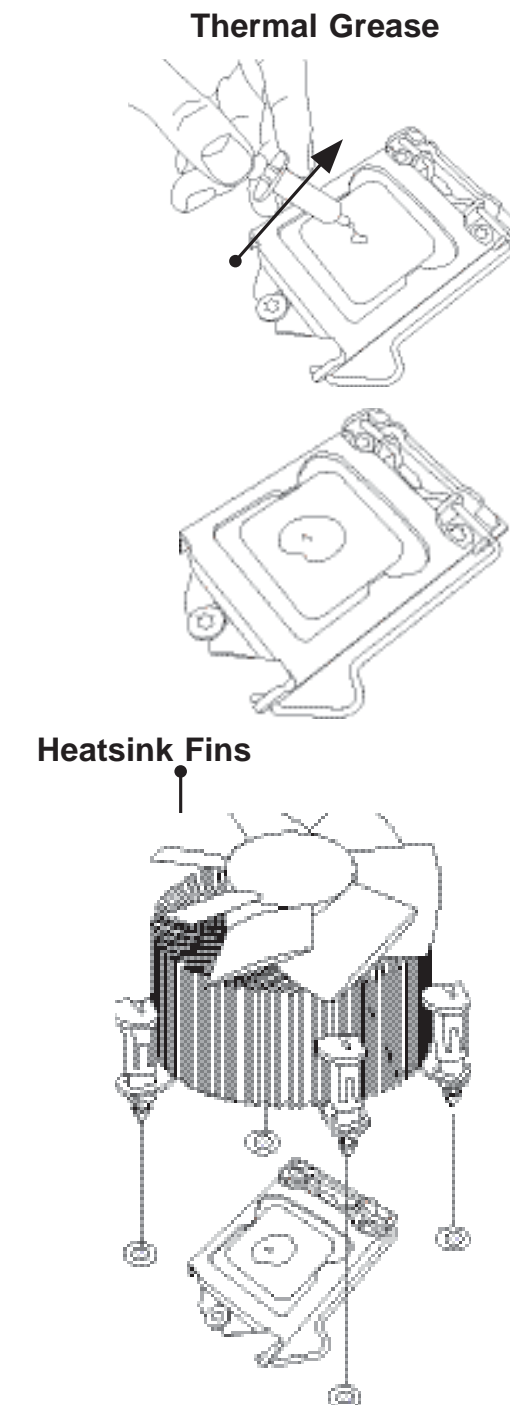

7. Align the four heatsink fasteners with the mounting holes on the motherboard. Gently push the pairs of diagonal fasteners (#1 & #2, and #3 & #4) into the mounting holes until you hear a click. Also, make sure to orient each fastener so that the narrow end of the groove is pointing outward.
8. Repeat Step 7 to insert all four heatsink fasteners into the mounting holes.
9. Once all four fasteners are securely inserted into the mounting holes and the heatsink is properly installed on the motherboard, connect the heatsink fan wires to the CPU fan connector.

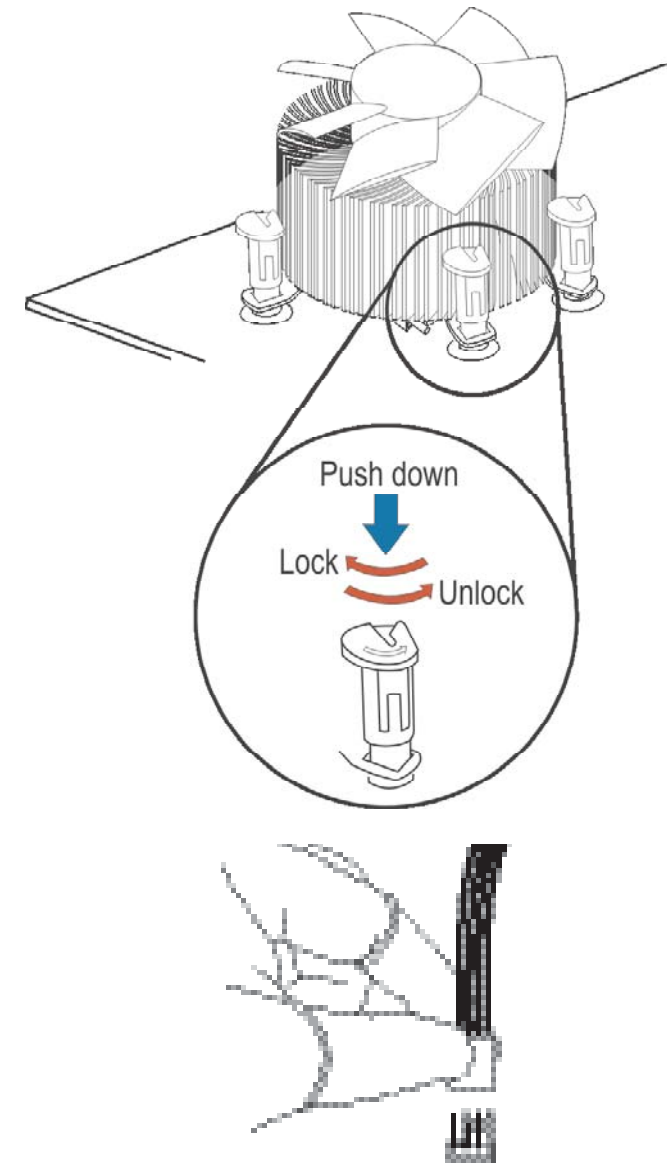

Chapter 3

CPU and Heatsink Removal

3-1 Heatsink Removal

To avoid damaging the CPU or related components, follow the instructions below to properly remove the CPU and the heatsink from the system.

Removing a Passive Heatsink

 **Warning:** We do not recommend that the CPU or the heatsink be removed. However, if you do need to remove the heatsink, please follow the instructions below to uninstall the heatsink and prevent damage to the CPU or other components.

1. Unplug the power cord from the power supply.
2. Disconnect the heatsink fan wires from the CPU fan header.
3. Use your finger tips to gently press on the fastener cap and turn it counterclockwise to make a 1/4 (90°) turn, and then pull the fastener upward to loosen it. Be sure to wear finger gloves before handling the CPU, the CPU socket and CPU-related components.
4. Repeat Step 3 to loosen all fasteners from the mounting holes.
5. With all fasteners loosened, remove the heatsink from the CPU.

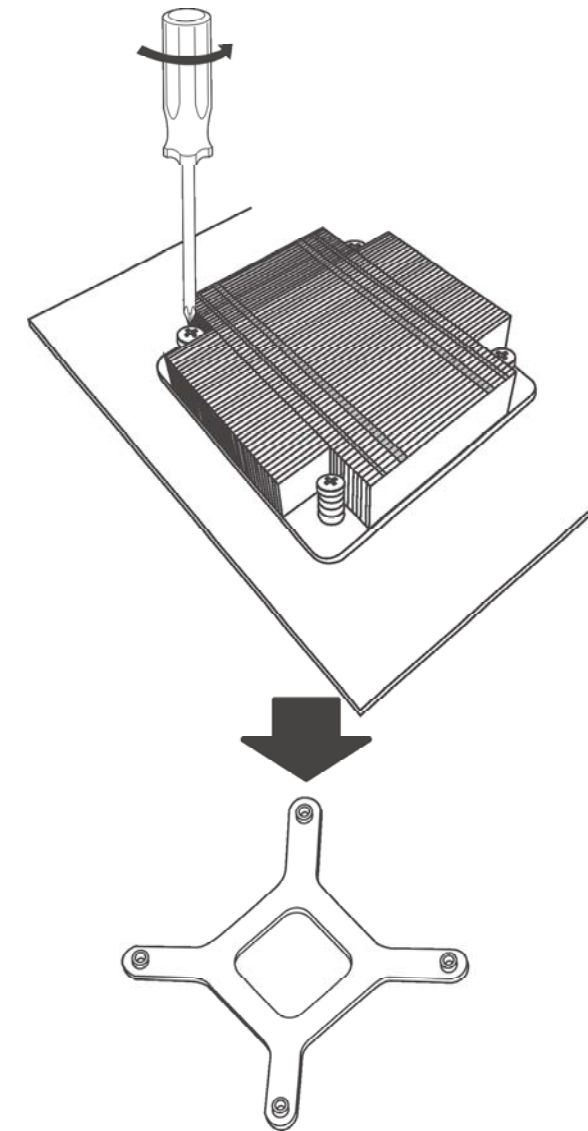

Removing an Active Heatsink



Warning: We do not recommend that the CPU or the heatsink be removed. However, if you do need to remove the heatsink, please follow the instructions below to remove the heatsink and to prevent damage done to the CPU or other components.

1. Unplug the power cord from the power supply.
2. Disconnect the heatsink fan wires from the CPU fan header.
3. Use your finger tips to gently press on the fastener cap and turn it counterclockwise to make a 1/4 (90°) turn, and pull the fastener upward to loosen it.
4. Repeat Step 3 to loosen all fasteners from the mounting holes.
5. With all fasteners loosened, remove the heatsink from the CPU.

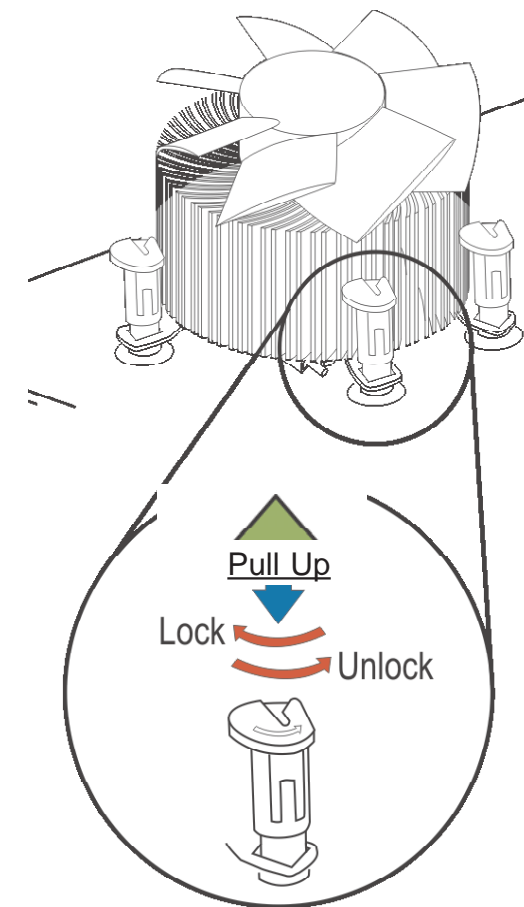
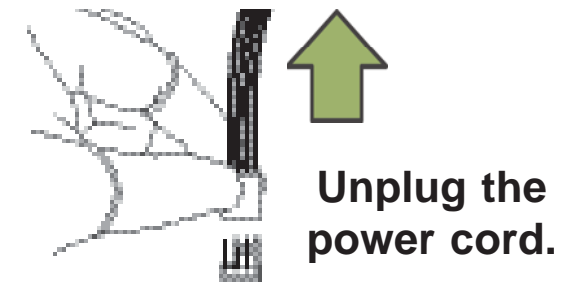

3-2 CPU Removal



Warning!

When handling the processor package, avoid placing direct pressure on the label area of the fan.

Opening the Load Plate

1. Use one hand to secure the motherboard, and use the other hand to press the socket clip to release the load plate, which covers the CPU socket, from its locked position.
2. Gently lift the socket clip to open the load plate.
3. Gently push the tab of the load plate to open the load plate.

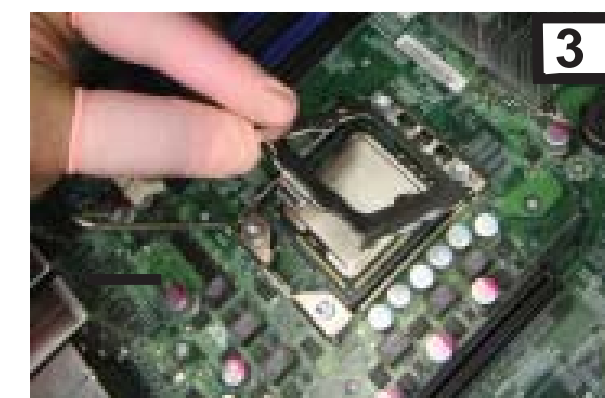
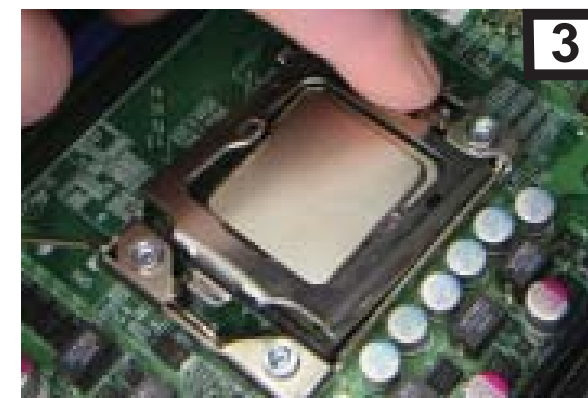
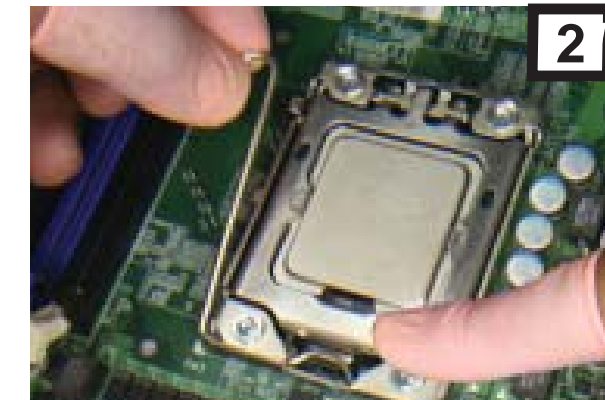
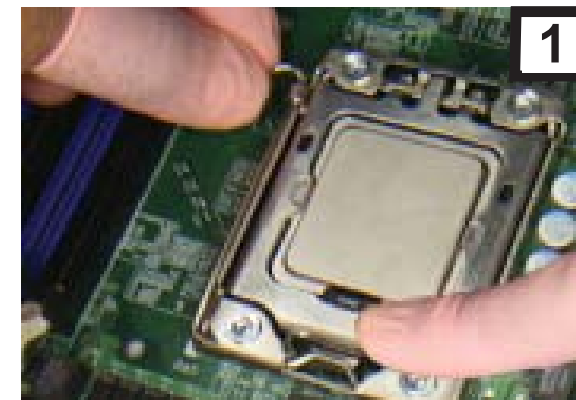

Removing the CPU from the CPU Socket

After opening the load plate, follow the instructions below to properly remove the CPU from the socket.

1. Locate the north center edge and the south center edge of the CPU.
2. Use the thumb and the index finger of one hand to hold the CPU at its north center edge and south center edge while securing the motherboard to its position with the other hand.
3. Pull the CPU straight up from the socket. Do not move the CPU horizontally to avoid the CPU pins from rubbing against socket pins.



Warning!

Do not tilt the CPU at an angle to prevent its edge from touching the CPU socket or brushing against the socket pins.

North Center Edge



South Center Edge

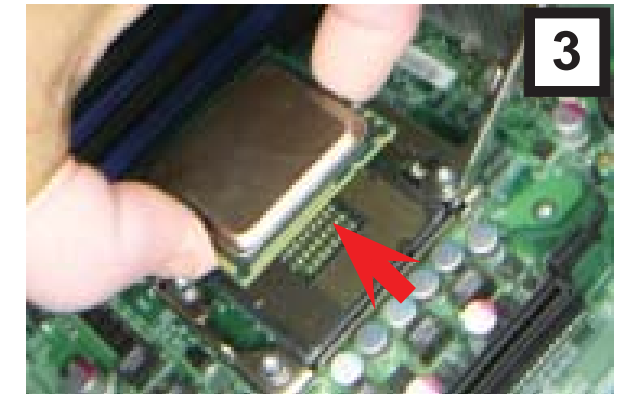
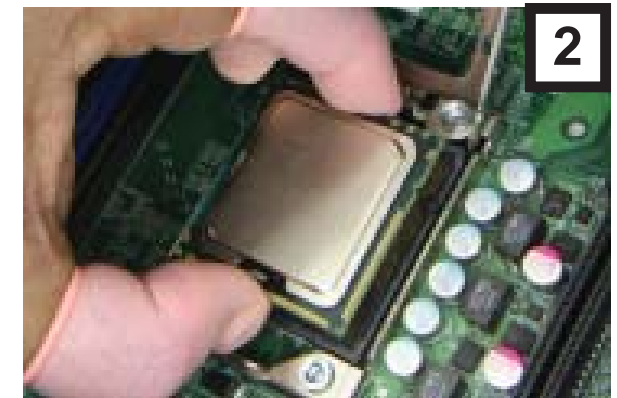

Placing the Plastic Cap on the CPU Socket

Warning!

Be sure to properly place the plastic cap on the CPU socket to protect the socket and its pins. In addition, the motherboard must be shipped with the plastic cap properly installed. Shipping without the plastic cap properly installed will cause damage to the socket pins, and void the manufacturer warranty.

1. Locate Pin 1 on the plastic cap, which is the triangle marked on a corner.
2. Locate the keys on the plastic cap, which are the semi-circle cutouts on the sides of the cap.
3. Align Pin 1 of the plastic cap with Pin 1 of the CPU socket and the keys of the plastic cap against the socket keys.
4. Once the plastic cap is properly aligned with the socket, lower the plastic cap straight down to the socket without moving it horizontally to prevent the plastic cap from damaging the socket pins.

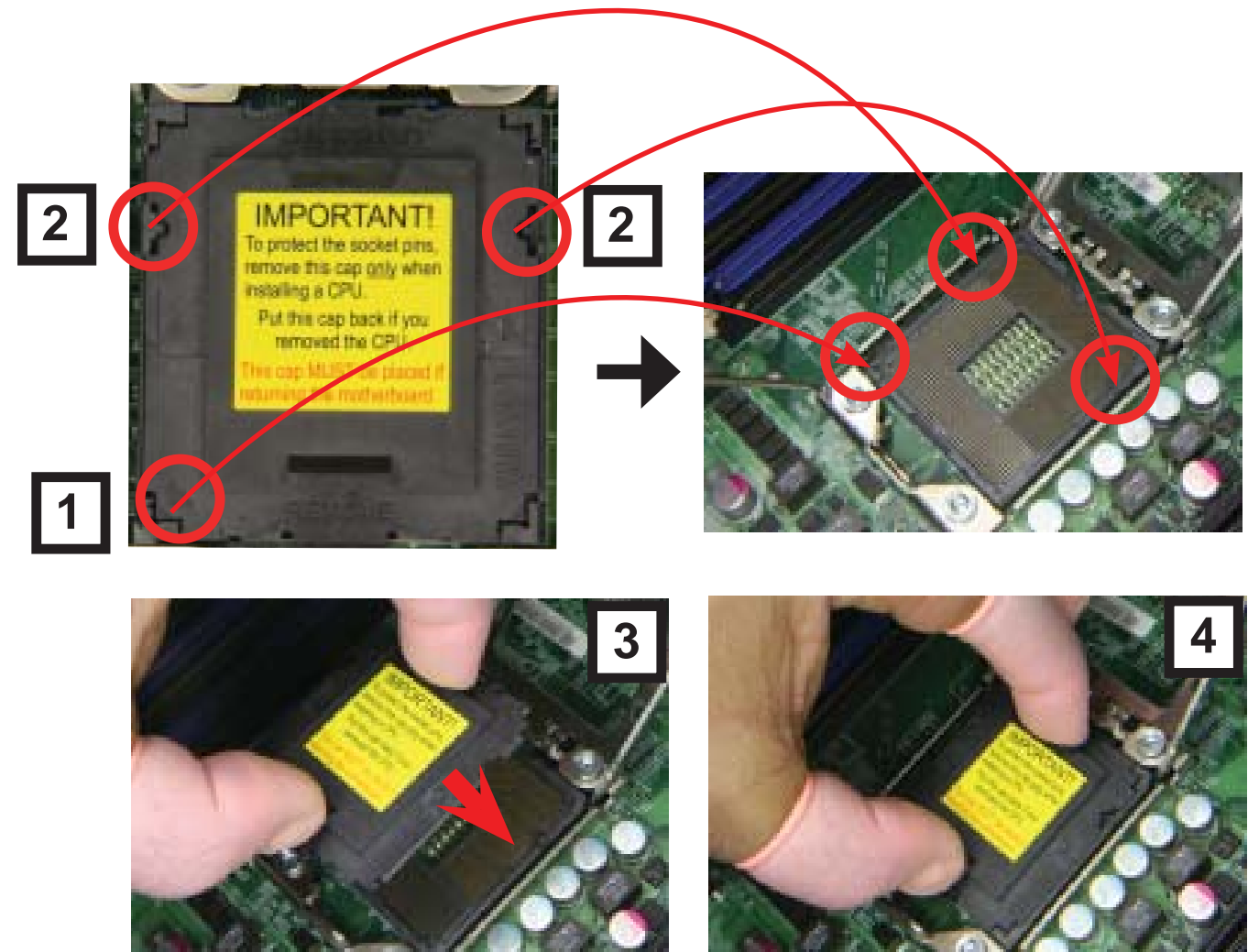

Warning!

Do not tilt the plastic cap at an angle to prevent its edge from touching the CPU socket or brushing against the socket pins.

Securing the Plastic Cap to the CPU Socket with the Load Plate

1. Once the plastic cap is properly seated on the socket, gently lower the load plate down to the plastic cap.
2. With the load plate on top of the plastic cap, use the index finger of one hand to gently press the load plate to secure it to the socket.
3. Using the thumb and the index finger of the other hand, pull the socket clip forward to engage the latch of the clip with the tip of the load plate.
4. Once the clip latch is on the top of the load plate, push the socket click down to lock it.



(Disclaimer Continued)

The products sold by Supermicro are not intended for and will not be used in life support systems, medical equipment, nuclear facilities or systems, aircraft, aircraft devices, aircraft/emergency communication devices or other critical systems whose failure to perform be reasonably expected to result in significant injury or loss of life or catastrophic property damage. Accordingly, Supermicro disclaims any and all liability, and should buyer use or sell such products for use in such ultra-hazardous applications, it does so entirely at its own risk. Furthermore, buyer agrees to fully indemnify, defend and hold Supermicro harmless for and against any and all claims, demands, actions, litigation, and proceedings of any kind arising out of or related to such ultra-hazardous use or sale.